

USER MANUAL

INALTO

INALTO.HOUSE

75cm Ceramic Cooktop

MODEL CODE/S

ICC705TB



A HIGHER LEVEL OF COOKING

V.4 | 1020

Welcome

Residentia Group Pty Ltd

—

Head Office

165 Barkly Avenue, Burnley
Victoria Australia 3066

—

Postage

PO Box 5177, Burnley
Victoria Australia 3121

—

ACN.

600 546 656

—

Online

residentia.group

Congratulations on purchasing your new appliance.
The InAlto brand is proudly distributed within Australia
by Residentia Group Pty Ltd.

Please refer to the warranty card at the rear of this manual for
information regarding your product's parts and labour warranty,
or visit us online at www.residentia.group

At Residentia Group, we are customer obsessed and our
Support Team are there to ensure you get the most out of your
appliance. Should you want to learn more about the various
features of your appliance, and importantly taking care of it
when cleaning, our Support Team are here to help. You can
use our online Support Centre at anytime by visiting:
<http://support.residentiagroup.com.au>

You can contact us via calling us on 1300 11 HELP (4357)
Or email us at: support@residentiagroup.com.au

It is important that you read through the following use and care
manual thoroughly to familiarise yourself with the installation
and operation requirements of your appliance to ensure
optimum performance. Please note, this manual has been
prepared for multiple models. Your appliance may not feature
some functions specified in the manual. Products marked with
(*) are optional.

Again, thank you for choosing an InAlto appliance and we look
forward to being of service to you.

Kind Regards,
The Residentia Team





02
WELCOME

04
SAFETY
INSTRUCTIONS

06
SPECIFICATIONS

08
USING YOUR
COOKTOP

09
OPERATING
YOUR COOKTOP

14
CLEANING &
MAINTENANCE

14
INSTALLATION

20
TROUBLESHOOTING

21
PURCHASE DETAILS

22
WARRANTY
INFORMATION

Safety Instructions

This cooktop must only be installed by a suitably qualified and licenced person and in accordance with the instructions provided. Incorrect installation may cause harm to persons, damage property and void the product's warranty.

IMPORTANT!

The electricity supply to the cooktop must be cut off before any adjustments or maintenance work is undertaken.

WARNING

When using this product, basic precautions should always be taken including the following:

- ▶ This cooktop is designed for domestic household use and for the cooking and frying of domestic foodstuffs.

IMPORTANT!

The adjacent furniture and all materials used in the installation must be able to withstand a minimum temperature of 85°C above the ambient temperature of the room it is located in, whilst in use.

- ▶ Certain types of vinyl or laminate kitchen cabinetry are particularly prone to heat damage or discolouration at temperatures above the guidelines given.
- ▶ Any damage caused by the cooktop being installed in contravention of this temperature limit, will be the liability of the owner.
- ▶ Your new cooktop is guaranteed against electrical or mechanical defects, subject to certain exclusions that are noted in the Warranty Terms and Conditions (at the rear of this user manual). The foregoing does not affect your statutory rights.
- ▶ The use of this cooktop for any other purpose or in any other environment, without the express agreement of Residentia Group, will invalidate any warranty or liability claim.
- ▶ You should not use this appliance to store items on or as a work surface.
- ▶ No modifications to the appliance are permitted by Residentia Group.
- ▶ You should not store or place flammable or highly flammable liquids/materials on top of or near the appliance. Items made from aluminium, plastic or plastic film should also be kept away from the appliance, as they may fuse to the surface.
- ▶ Repairs may only be carried out by authorised service agents.
- ▶ Your Inalto cooktop is not to be used by children or persons with reduced physical, sensory or mental capabilities, or lack of experience and knowledge, unless they have been given supervision or instruction.
- ▶ Any film or stickers that are present on the cooktop when it is delivered should be removed before use.
- ▶ Care should be used when utilising the cooktop, otherwise there is a risk of burns being caused.
- ▶ You should not allow the electrical connection cables to come into contact with the cooktop surface when it is hot or any hot cookware.
- ▶ If fat and oil overheats, then it can ignite extremely quickly. For this reason, when cooking with fat and oil the appliance should not be left unattended.
- ▶ Make sure that all of the cooking zones are switched off after use.
- ▶ Cleaning of the cooktop should be carried out on a regular basis, once the cooktop has cooled down.
- ▶ Great care should be taken whilst using this appliance and when following the cleaning procedure.
- ▶ You should not use a steam jet or any other high pressure cleaning equipment to clean the appliance.

**DECLARATION OF CONFORMITY**

The manufacturer declares that the cooktop is built using certified materials and requires the appliance to be installed in accordance with the standards currently in force. This appliance must be used by a trained person for domestic purposes only.

TO AVOID DAMAGING YOUR COOKTOP

- ▶ The ceramic glass can be damaged by objects falling onto it.
- ▶ The ceramic glass edge can be damaged by knocks from cookware.
- ▶ Cast iron and cast aluminium cookware with damaged bases may scratch the ceramic surface if they are dragged across it.
- ▶ Pans should be lifted on and off the cooktop surface and not dragged.
- ▶ Cooking zones should not be switched on without cookware placed on it. Also the cookware should not be empty.

UNPACKING

During transportation, protective packaging was used to protect the appliance against any damage. After unpacking, please dispose of all elements of packaging in a way that will not cause damage to the environment. All materials used for packaging the appliance are environmentally friendly; they are 100% recyclable and are marked with the appropriate symbol.

- ▶ During unpacking, the packaging materials (polythene bags, polystyrene pieces, etc.) should be kept out of reach of children.

DISPOSAL OF THE APPLIANCE

Old appliances should not simply be disposed of with normal household waste, but should be delivered to a collection and recycling centre for electric and electronic equipment. A symbol shown on the product, the instruction manual or the packaging shows that it is suitable for recycling.

Materials used inside the appliance are recyclable and are labelled with information concerning this. By recycling materials or other parts from used devices you are making a significant contribution to the protection of our environment.

Information on appropriate disposal centres for used devices can be provided by your local authority.

Specifications

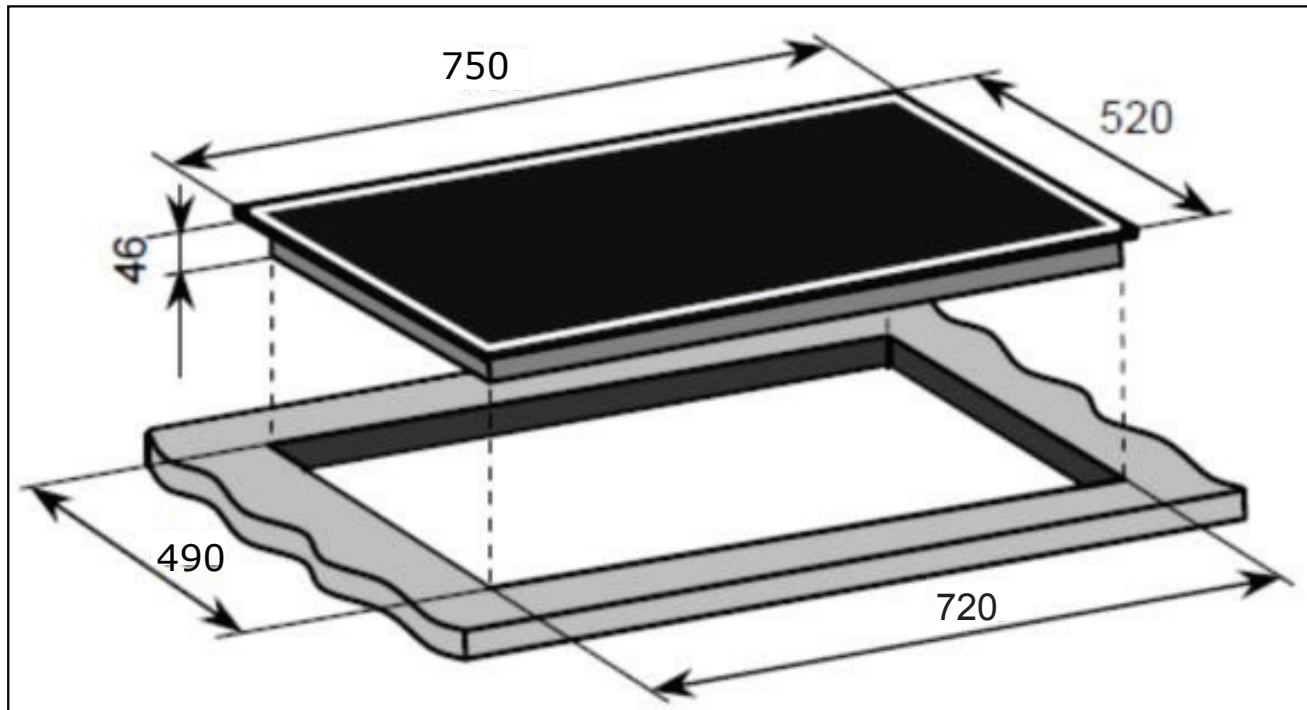
**Product dimensions:**

Depth: 520 mm
Width: 750 mm
Height: 46 mm

Aperture dimensions:

Depth: 490 mm
Width: 720 mm

Product specifications:

- 1 x 1.00 / 2.10 kW double zone (Ø 140/240 mm)
- 1 x 1.40 / 2.20 kW oval zone (Ø 170/265 mm)
- 1 x 1.80 kW zone (Ø 180 mm)
- 1 x 1.20 kW zone (Ø 145 mm)

- Front touch control operation
- 4 individual residual heat indicators
- Safety lock
- Timer
- Stainless steel frame

Electrical details

Rated Voltage:	220 – 240V~/380-415V 2N~ 50/60 Hz
Supply Connection:	16 A (double pole switched fused outlet with 3mm contact gap)
Max Rated Inputs:	7.3 kW
Mains Supply Lead:	3 core x 6 mm ² (not supplied)

Ceramic hob surface layout

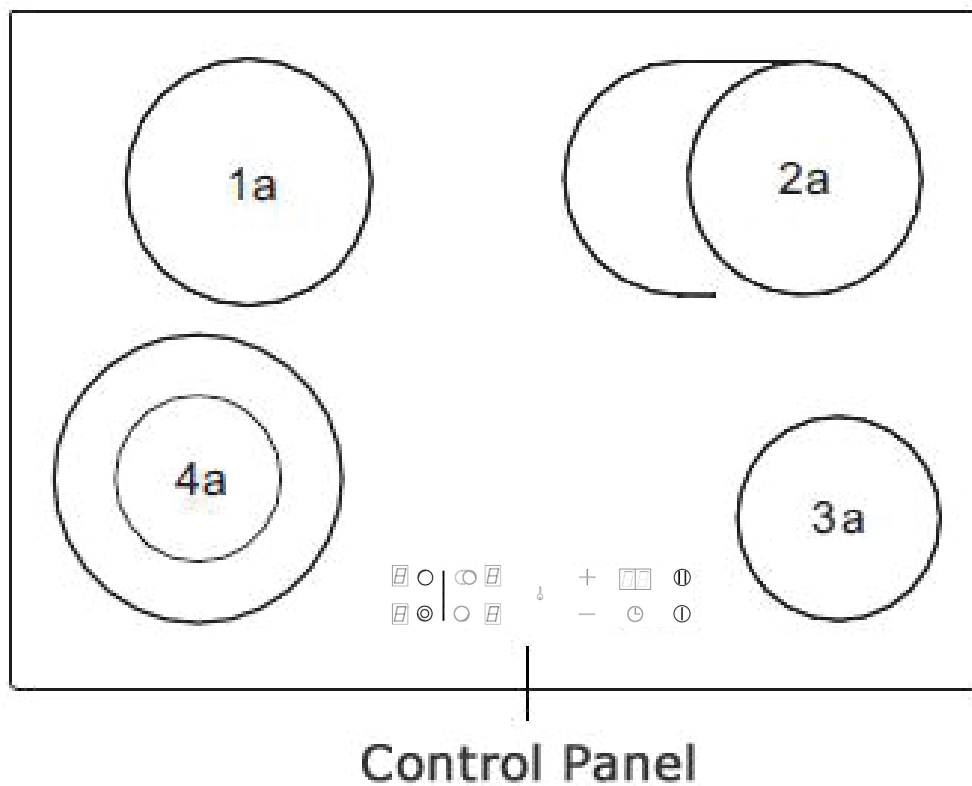

- 1a) 1 x 1.80 kW zone (Ø 180 mm)
- 2a) 1 x 1.40 / 2.20 kW oval zone (Ø 170/265 mm)
- 3a) 1.20 kW zone (Ø 145 mm)
- 4a) 1.00 / 2.10 kW double zone (Ø 140/240 mm)

Control panel layout

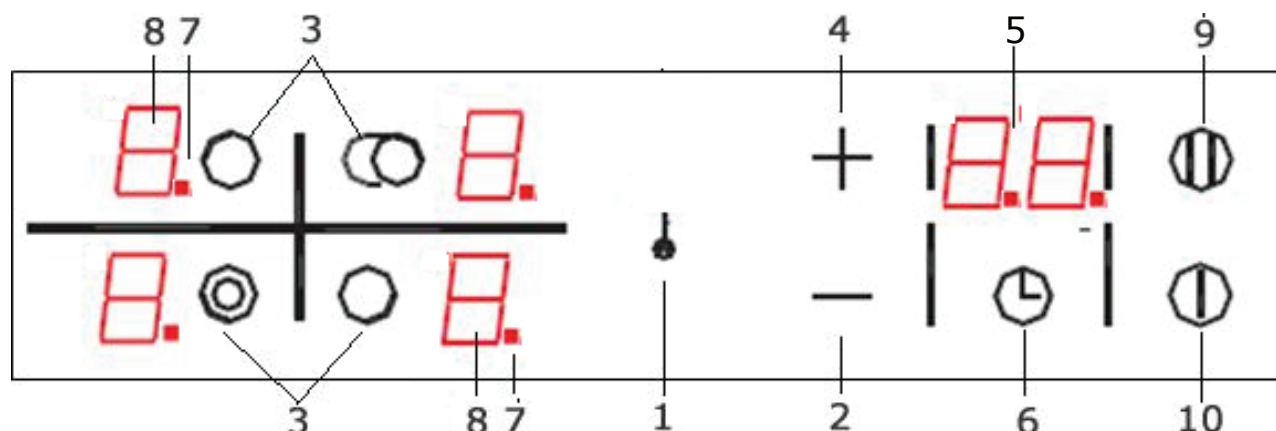

1. Safety lock button
2. Minus button
3. Cooking zone selection buttons
4. Plus button
5. Timer display
6. Timer button
7. Zone timer activated LED
8. Zone temperature display
9. Pause button
10. Power button

Using the ceramic hob

Before first use



IMPORTANT: You should clean the ceramic hob surface. Please see the "Cleaning and maintenance" section.

- You should switch on one cooking zone at a time, for 5 minutes at the maximum setting. This will help to eliminate any new smell that exists and evaporate any humidity that has formed on the heating elements during transit.
- Do not burn off more than one zone at once.
- **You must** place a saucepan filled half full with cold water on each zone as you burn it off.

Touch controls

- All operations are performed by means of the touch controls that can be found on the control panel.
- Each touch control has a visual display that corresponds to it.

Switching the hob top on and off

- Press the power button (**11**) to switch on the appliance.
- Pressing the power button again will turn the whole hob off.

Operating procedures and function instructions.

1. After the power is on, the digital tube will be fully lit for 2 seconds, the buzzer will sound, then it will go into hibernation, and the digital tube will not be displayed.
2. The power button is the superlative button, which can be operated under any circumstance.
3. When the power is not turned on, other keys cannot be operated except for the child lock key.
4. Press the power button to start the power, all digital tubes display "--", and enter standby mode. If the standby machine does not operate within 1 minute, automatically turn off the power and display and go to sleep. The power was shut down for a long time.



5. Lock the keyboard according to the child lock key, and the two digital tubes on the right show "Lo", and the child lock should be removed for 3 seconds. Child lock can also be unlocked when power is not turned on. If there is a timing function, "Lo" alternates with the timing time, and the switching frequency is 1 second.

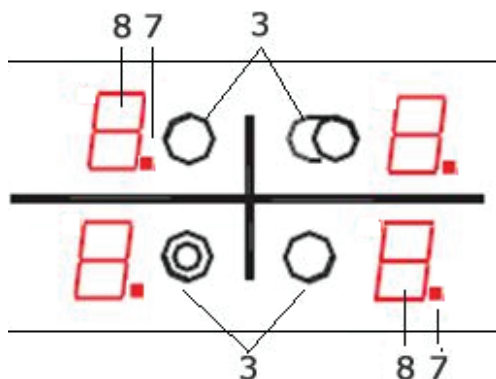

Switching on a zone and setting a power level

- press the "boiler plate" button to start the barbecue function, corresponding to the digital tube scintillation display gear (the default is 5 files), then click "add" and "subtract" button to adjust the gear position.
- The cycle can be adjustable from 0 to 9, with a long press "plus" or "minus" button, and the gear can be adjusted rapidly and continuously. At the same time, press the "add" and "subtract" button, and the gear is reset to zero.
- During the operation of the furnace plate, press the "furnace plate" button, and the digital tube flashes, which can be adjusted again.
- Press the power button to close all the furnace plates directly.
- Press the "+" and "-" key to quickly close the selected work area.
- The opening time of the stall (s) :

Gera	0	1	2	3	4	5	6	7	8	9
Work time	0	2	7	11	13	17	23	31	42	60
Off time	60	58	53	49	47	43	37	29	18	0

Note: no.2 boiler plate 3 is the energy efficiency file, and the power supply time is 9 seconds.

Multi-ring adjustment

- disk, containing polycyclic mode of furnace, the default open only the inner ring, can be selected in furnace set (furnace plate flashing), press the furnace plate button again, can let the furnace plate work in double or three-ring model.
- switch order, inner ring, double ring, triple ring, inner ring.
- The inner ring mode displays "_", the double loop mode displays "=", and the three-ring mode displays "harmony".
- In the running process, the gear position and ring number are displayed alternately.

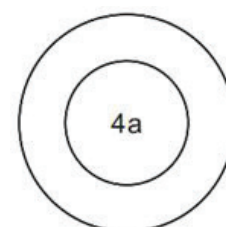
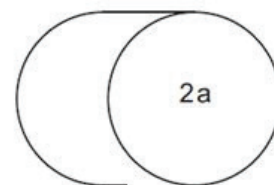

Suspension

- A. and plate heating furnace in the process, if you want to suspend this furnace operation (heating, timing), can be selected

in furnace set, press "pause" button to suspend operation, display "P" suspended after the furnace plate.

- B. After the suspension, it is still possible to set gear, multi-ring and timing of the furnace plate.
- C. After the boiler plate is suspended, it wants to resume its operation, and can be restored by pressing the "pause" button when the furnace plate is selected.

IMPORTANT: Use caution when using this function and be sure to check that all required zones are in use and at the desired heating level.

Alarm clock and timing operation

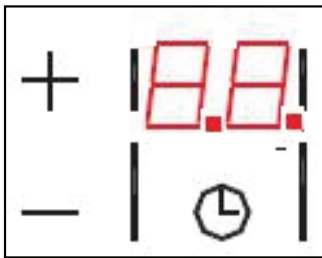

- A. The operation time or the boiler plate is not in the setting state, and the alarm setting can be set according to the "time" key.
- B. When the furnace tray is flashing, press the "timing" button to set the barbecue timing, and the small dots will be displayed in the lower right corner of the gear.
- C, after entering set, bits digital tube twinkle, at this time can only be set bits of time, then click on the "time" button, the ten the digital tube twinkle, at this time can be set up ten time, press the "time" button to confirm again, or automatically after 5 seconds.
- D, press "add" or "subtract" button to adjust the time quickly; At the same time press "add", "subtract" key, clear time.
- E. Set ranges from 0 to 99 minutes.
- F, alarm clock and grill time are independent of each other. If there are multiple timers at the same time, it will only show the original end and flicker the dots on the corresponding furnace digital tube. In the case of alarm clock time, all the digital tubes in the furnace will not flicker to show the dot.
- G. When the alarm clock is over, the buzzer will give 10 sounds, which can be cancelled according to any key during the call.
- H. After the barbecue, the buzzer prompts 10 sounds, and the prompt can be cancelled according to any key during the call.

Residual temperature

- A. After the furnace plate is heated, the corresponding digital tube will flash display "H", indicating the high temperature.
- B. The display time is as follows:
- The burner is open for 3 seconds and "H" is not displayed.
- Open the burner for 3-10 seconds, and "H" for 10 minutes.
- The burner is open for more than 10 seconds, and "H" shows 45 minutes.
- Continuous work. H shows up to 45 minutes at most. H time has existed.

No stall, no H, no alarm clock, automatically turn off the power and display after 60 seconds, and the buzzer will go into hibernation.

After no operation for 2 hours, the machine will stop automatically, and the buzzer will ring 10, and the prompt can be cancelled according to any key during the call.

Overflow for 8 seconds, automatically stop, and the buzzer will ring, showing E4.

The NTC reaches a temperature of 95 degrees and is shut down. E3 is shown above 95 degrees.

High temperature downshift

- A. Use time and temperature to control the downshift.
- B. Open 4 furnace heads at the same time to carry out the downshift.
- C. Downshift description:
 - · run 6 for 20 minutes, run 3 for 15 minutes, and run 6 for 15 minutes.
 - · the NTC reached 80 degrees and all fell to 1.

Hob guidelines

- The first few times the hob top is used, it may give off an acrid, burning smell. This smell will disappear completely with repeated use.
- The worktop is fitted with cooking areas of different diameter and power.
- The positions where the heat will radiate from are clearly marked on the hob top. The saucepans must be positioned exactly on these zones for efficient heating to occur. Pans should have the same diameter as the cooking zone that they are being used on.
- You should not use saucepans with rough bottoms, as this can scratch the ceramic surface.



- Before use, make sure that the bottoms of the saucepans are clean and dry.
- When cold, the bottom of the pans should be slightly concave, as they expand when hot and lie flat on the surface of the hob. This will allow the heat to transfer more easily.
- The best thickness for the bottom of the pans is 2 – 3 mm of enamelled steel and 4 – 6 mm for stainless steel with sandwich type bottoms.
- If these rules are not followed, then there will be a great loss of heat and energy. Heat not absorbed by the saucepan, will spread to the hob, frame and surrounding cabinets.
- Preferably cover pans with a lid to permit cooking at a lower heat.
- Always cook vegetables and potatoes, etc. in as little water to reduce cooking times.
- Food or liquid that has high sugar content may damage the hob top if it comes into contact with the ceramic hob surface. Any spillages should be wiped up immediately, however this may not prevent the hob surface from becoming damaged.
- ***IMPORTANT:*** *The ceramic hob surface is tough; however it is not unbreakable and can be damaged. Especially if pointed or hard objects are allowed to fall on it with some force.*
- ***DO NOT USE THE HOB IF THE SURFACE BECOMES BROKEN OR CRACKED. YOU SHOULD CONTACT THE CUSTOMER CARE DEPARTMENT IMMEDIATELY.***

Cleaning and maintenance



Cleaning operations must only be carried out when the hob is cool.

The appliance should be disconnected from your mains supply before commencing any cleaning process.

Cleaning the ceramic hob top



Any residues that are left on the hob top surface from cleaning agents **will** damage it. You should remove any residues with warm water mixed with a little washing up liquid.



Abrasive cleaners or sharp objects will damage the hob surface; you should clean it using warm water mixed with a little washing up liquid.



You may find it easier to clean some deposits whilst the hob surface is still warm. However you should take care not to burn yourself if cleaning the hob surface when it is still warm.

After each use

- Wipe the appliance over with a damp cloth.
- Dry the appliance by rubbing the surface with a clean cloth.

Installation



The installation must be carried out by a suitably qualified person, in accordance with the current version of the following.

- ***UK Regulations and Safety Standards or their European Norm Replacements.***
- ***Building Regulations*** (issued by the Department of the Environment).
- ***Building Standards*** (issued by the Scottish Development Department).
- ***IEE Wiring Regulations.***
- ***Electricity At Work Regulations.***

Positioning



The adjacent furniture must be able to withstand a minimum temperature rise of 85°C above the ambient temperature of the room it is located in, during periods of use.

This appliance is classified as Class 3 and therefore is to be built into a kitchen unit (depending on size) or 600 mm worktop that is at least 30 mm thick. The following minimum clearance distances must be observed:-

- 700 mm between the hob surface and the underside of any horizontal surface above it.
- 50 mm clearance around the front, back and sides of the appliance, measured from the cut out.
- If the hob is positioned so that the right or left hand side of the appliance will be near to the edge of a kitchen unit. There must be a gap of at least 150 mm between the side of the hob and the vertical surface of the kitchen unit.

Installing the appliance

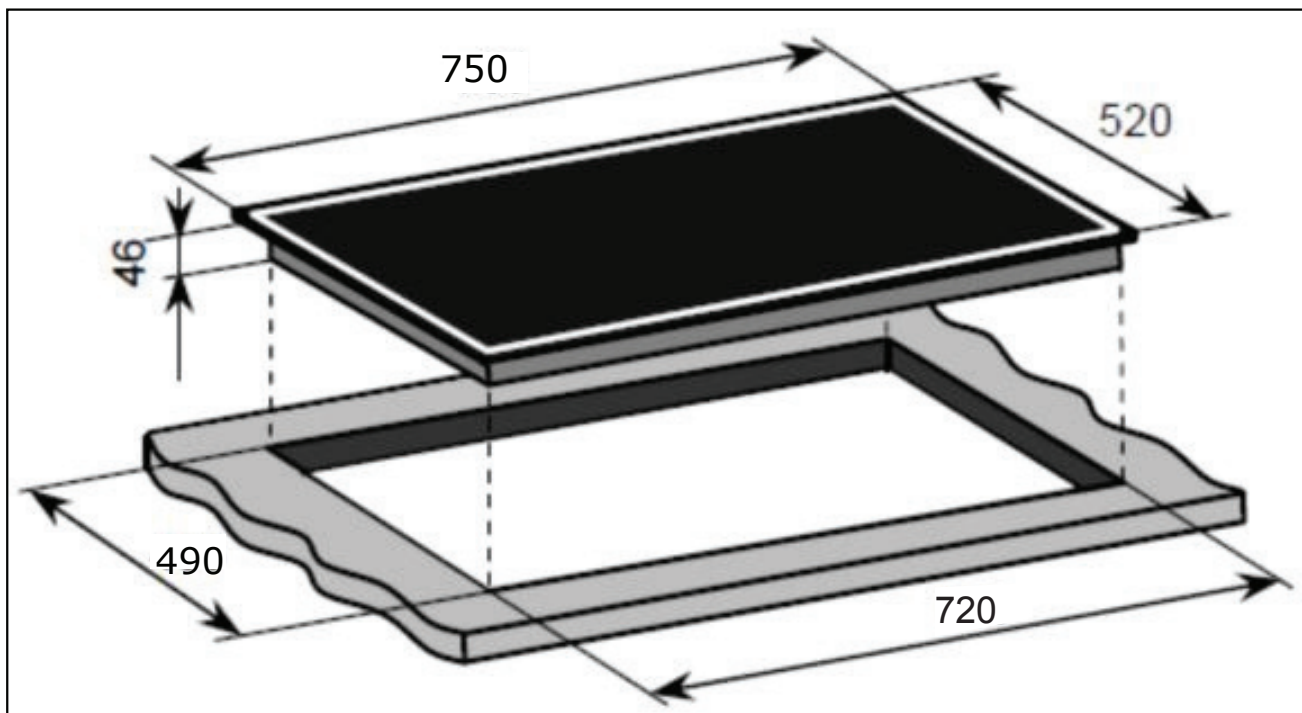

- Cut a hole in the worktop that corresponds with the drawing shown above.

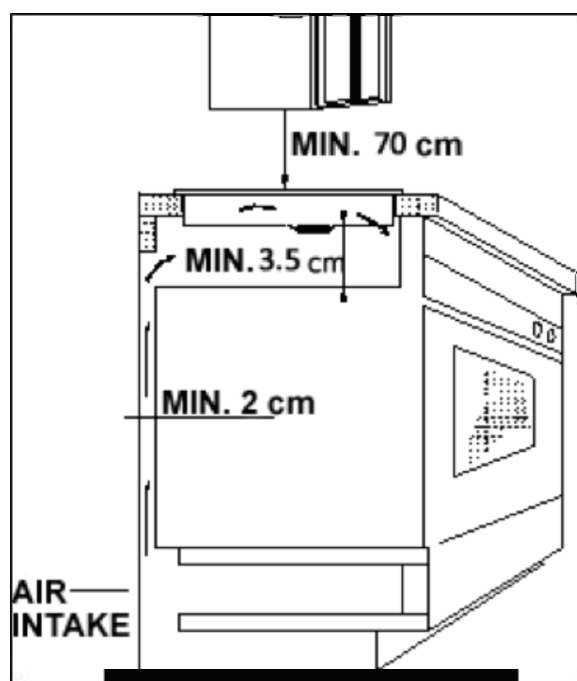

- **IMPORTANT:** You must observe the ventilation requirements shown in the drawing opposite.
- The air intake vent can be at the rear wall or in the base area. There is no need for venting at the front of the hob.
- If the hob is installed above drawers or a cupboard then a separator board must be placed no less than 3.5 cm below the hob with at least a 2 cm gap at the rear.
- If the hob is installed above drawers or a cupboard there is no need for a separate air intake.

Applying the Seal

The installation hardware includes a quantity of sealing tape which, when applied around the cooktop, prevents liquid from entering the cabinet. Follow the instructions below in order to correctly apply this seal.

- Detach the backing strip from sealing tape but ensure that the transparent adhesive still adheres to the seal itself.
- Turn over the cooktop and correctly position the sealing tape under the edge of the cooktop, ensuring that the outer part of the seal perfectly matches the outer edge of the cooktop (Fig. 3).

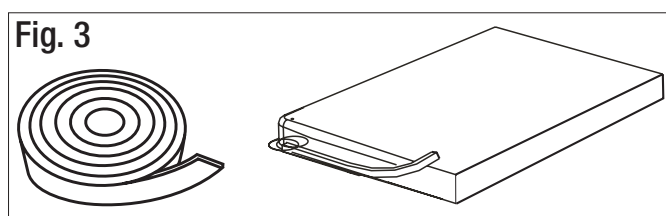

- Evenly and securely fix the seal to the hob, pressing it firmly in place.

Inserting and Fixing the Cooktop

- Carefully lower the cooktop into the aperture hole that you have cut out.
- Using the screws provided, affix the 4 brackets to the underside of the cooktop, as illustrated (Fig. 4).
- Adjust the bracket position to suit your benchtop thickness (Fig. 5).

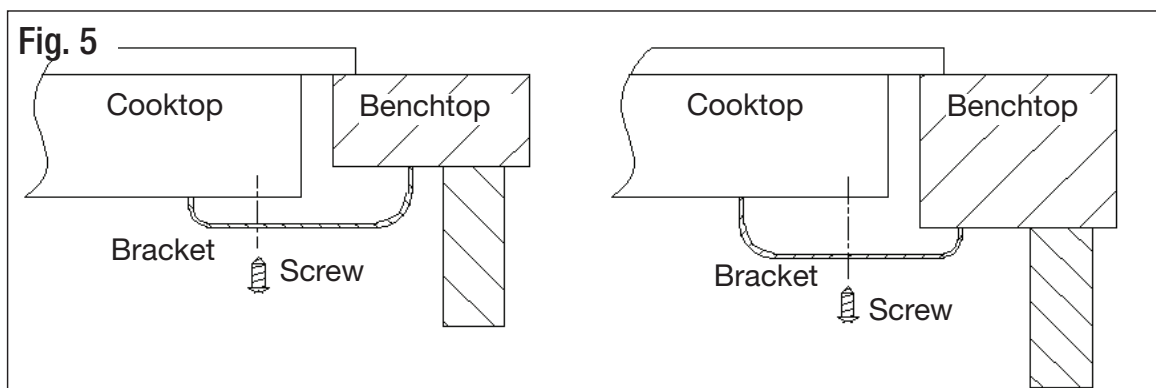
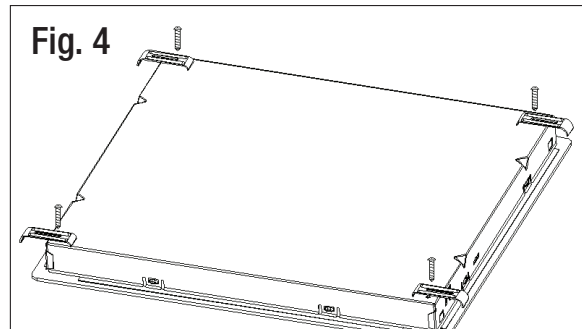

Electrical connection



This appliance must be installed by a qualified person in accordance with the latest edition of the I.E.E. Regulations and in compliance with our instructions.

Before connecting the appliance, make sure that the supply voltage marked on the rating plate corresponds with your mains supply voltage.

WARNING: THIS APPLIANCE MUST BE EARTHED.

- This appliance must be wired into a 16 A double pole switched fused spur outlet, having 3 mm contact separation and placed in an easily accessible position adjacent to the appliance. It should not be located above the appliance and no more than 1.25m away from it.
- The spur outlet must still be accessible even when your hob is located in its operating position.

Cable type: H05 RRF 3 core x 6 mm²

Connecting the mains supply cable

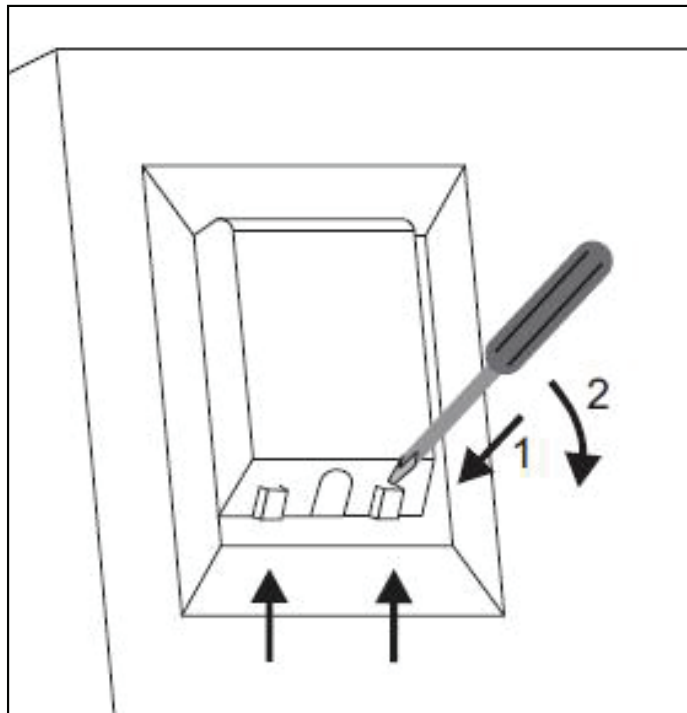

- The mains terminal block is located on the underside of the hob and the terminals are accessible by removing the terminal block cover. This is done by depressing the front of the cover and releasing it from the securing clips.

CONNECTION DIAGRAM Caution: Voltage of heating elements 220-240V~/380-415V 2N~/380-415V 3N~ Caution! In the event of any connection the safety wire must be connected to the PE terminal	
For 220-240V~ , L to be connected to terminals 1-2-3 with connection link, N to be connected to terminals 4-5 with connection link, The safety wire must be connected to the PE terminal	
For 380-415V 2N~, L1 to be connected to terminal 1, L2 to be connected to terminal 2-3 N to be connected to terminals 4-5 with connection link. The safety wire must be connected to the PE terminal	
For 380-415V 3N~, L1 to be connected to terminal 1, L2 to be connected to terminal 2, L3 to be connected to terminal 3, N to be connected to terminals 4-5 with connection link. The safety wire must be connected to the PE terminal	

- The cable connections must be in accordance with the diagram located on the bottom of the hob (see above). The links must also be positioned as indicated.
- You should use a good quality screwdriver to carefully, fully tighten ALL of the terminal screws.
- ***If when the hob is first switched on, only two of the zones work, you should recheck that the terminal screws are all fully tightened and the links are in position. This should be done before contacting the Customer Care Department.***
- The cable can be looped if necessary, but make sure that is not kinked or trapped when the hob is in position. Care must be taken to avoid the cable being in contact with hot parts of the appliance.

Replacing the mains supply cable

If the mains supply cable is damaged, then it must be replaced by an appropriate replacement.

The mains supply cable should be replaced in accordance with the instructions on the next page:

- ***Switch the appliance off at the socket.***
- Open the terminal block on the underside of the hob.
- Unscrew the terminal screws fixing the cable.
- Replace the cable with one of the same length and in accordance with the specification given on page 21.
- The "green-yellow" earth wire must be connected to the terminal marked . It must be about 10 mm longer than the live and neutral wires.
- The "blue" neutral wire must be connected to the terminal marked with letter (N) - the live wire must be connected to the terminal marked with letter (L).

Troubleshooting

Please read the issues below carefully and try all relevant steps.
If none of this helps, please contact us on 1300 11 4357 for further advice or to schedule a technician to inspect your cooktop.

Tips & Hints

THE COOKING ZONES ARE NOT FUNCTIONING

Please check...

That your cooktop is plugged in and there is power to the wall socket.

Hint: Check the mains power or the isolation switch.

If your cooktop has a Control Lock or Child Lock function, check that it is switched off.

THE RESIDUAL HEAT INDICATOR DOES NOT APPEAR

Please note...

If the cooking zone has only been turned on for less than 30 seconds, the residual heat indicator will not appear.

If the cooking zone does appear to be hotter than 50° C or has been activated for longer than 30 seconds, and the residual heat indicator has not come on, please contact our Support Team on 1300 11 4357 for advice.

THE COOKTOP IS HUMMING WHEN A ZONE IS SELECTED

Please note...

This is normal—the sound will disappear when the zone heats up.

If the humming sound continues once the zone is fully at heat, please contact our Support Team on 1300 11 4357 for advice.

THE ELEMENTS STAY ON HIGH

Please...

Contact our Support Team on 1300 11 4357 to arrange for a technician to visit.

THE GLASS IS SCRATCHED

Please note...

Scratches are often caused by using cookware with rough-edges. Please ensure pots and pans have smooth bases.

THE COOKTOP IS NOT TURNING OFF

Please...

Ensure the child lock is disabled.

Hint: On some models you may have to touch the zone control twice to disable.

THE COOKING ZONES HAVE BECOME DISCOLOURED

Please note...

This may be caused by burnt on remnants of food. This will not affect the working of the appliance however you should make sure that the cleaning instructions are being followed regularly.

THE COOKTOP IS DIRTY AFTER COOKING

Please note...

Once it has cooled down, your cooktop should be cleaned after every use. Any residues that are left on the cooktop surface from cleaning agents will damage it. You should remove any residues with warm water mixed with a little washing up liquid.

Hint: For physical deposits on the surface, a specialist ceramic cooktop cleaner/conditioner should be purchased. Please follow the instructions with this product.

THERE IS A METALLIC SHEEN ON THE GLASS

Please note...

This is often caused by pots with aluminium or copper bases.

Hint: Specialist ceramic cleaner should remove the marks. Your cooktop should be cleaned regularly, as spills that are allowed to burn into the surface may react with the ceramic glass and become much harder to remove.



Purchase Details

For future reference, please record the following information which can be found on the rating plate and the date of purchase which can be found on your sales invoice.

The rating plate of your hob is located on the underneath of the appliance. Therefore please fit the duplicate data plates or label on the outside of the cupboard to sure that the label can be easily seen during operation.

STORE DETAILS

STORE NAME | _____

ADDRESS | _____

TELEPHONE | _____

PURCHASE DATE | _____

PRODUCT DETAILS

MODEL NO. | _____

SERIAL NO.* | _____

Warranty Information

WARRANTY TERMS & CONDITIONS COOKING APPLIANCES (BUILT-IN OVENS, COOKTOPS)

This document sets out the terms and conditions of the product warranties for Residentia Group Appliances. It is an important document. Please keep it with your proof of purchase documents in a safe place for future reference should you require service for your Appliance.

- 1. IN THIS WARRANTY**
 - (a) 'acceptable quality' as referred to in clause 10 of this warranty has the same meaning referred to in the ACL;
 - (b) 'ACL' means Trade Practices Amendment (Australian Consumer Law) Act (No.2) 2010;
 - (c) 'Appliance' means any Residentia Group product purchased by you accompanied by this document;
 - (d) 'ASR' means Residentia Group authorised service representative;
 - (e) 'Residentia Group' means Residentia Group Pty Ltd of 118 Campbell St, Collingwood VIC, ACN 600 546 656 in respect of Appliances purchased in Australia;
 - (f) 'major failure' as referred to in clause 10 of this warranty has the same meaning referred to in the ACL and includes a situation when an Appliance cannot be repaired or it is uneconomic for Residentia Group, at its discretion, to repair an Appliance during the Warranty Period;
 - (g) 'Warranty Period' means:
 - (i) where the Appliance is used for personal, domestic or household use (i.e. normal single family use) as set out in the instruction manual, the Appliance is warranted against manufacturing defects for 24 months, following the date of original purchase of the Appliance;
 - (h) 'you' means the purchaser of the Appliance not having purchased the Appliance for re-sale, and 'your' has a corresponding meaning.
- 2.** This warranty only applies to Appliances purchased and used in Australia and is in addition to (and does not exclude, restrict, or modify in any way) any non-excludable statutory warranties in Australia.
- 3.** During the Warranty Period Residentia Group or its ASR will, at no extra charge if your Appliance is readily accessible for service, without special equipment and subject to these terms and conditions, repair or replace any parts which it considers to be defective. Residentia Group or its ASR may use remanufactured parts to repair your Appliance. You agree that any replaced Appliances or parts become the property of Residentia Group. This warranty does not apply to light globes, batteries, filters or similar perishable parts.
- 4.** Parts and Appliances not supplied by Residentia Group are not covered by this warranty.



5. You will bear the cost of transportation, travel and delivery of the Appliance to and from Residentia Group or its ASR. If you reside outside of the service area, you will bear the cost of:
 - (a) travel of an authorised representative;
 - (b) transportation and delivery of the Appliance to and from Residentia Group or its ASR, in all instances, unless the Appliance is transported by Residentia Group or its ASR, the Appliance is transported at the owner's cost and risk while in transit to and from Residentia Group or its ASR.
6. Proof of purchase is required before you can make a claim under this warranty.
7. You may not make a claim under this warranty unless the defect claimed is due to faulty or defective parts or workmanship. Residentia Group is not liable in the following situations (which are not exhaustive):
 - (a) the Appliance is damaged by:
 - (i) accident
 - (ii) misuse or abuse, including failure to properly maintain or service
 - (iii) normal wear and tear
 - (iv) power surges, electrical storm damage or incorrect power supply
 - (v) incomplete or improper installation
 - (vi) incorrect, improper or inappropriate operation
 - (vii) insect or vermin infestation
 - (viii) failure to comply with any additional instructions supplied with the Appliance;
 - (b) the Appliance is modified without authority from Residentia Group in writing;
 - (c) the Appliance's serial number or warranty seal has been removed or defaced;
 - (d) the Appliance was serviced or repaired by anyone other than Residentia Group, an authorised repairer or ASR.
8. This warranty, the contract to which it relates and the relationship between you and Residentia Group are governed by the law applicable where the Appliance was purchased.
9. To the extent permitted by law, Residentia Group excludes all warranties and liabilities (other than as contained in this document) including liability for any loss or damage whether direct or indirect arising from your purchase, use or non use of the Appliance.
10. For Appliances and services provided by Residentia Group in Australia, the Appliances come with a guarantee by Residentia Group that cannot be excluded under the Australian Consumer Law. You are entitled to a replacement or refund for a major failure and for compensation for any other reasonably foreseeable loss or damage. You are also entitled to have the Appliance repaired or replaced if the Appliance fails to be of acceptable quality and the failure does not amount to a major failure. The benefits to you given by this warranty are in addition to your other rights and remedies under a law in relation to the Appliances or services to which the warranty relates.
11. At all times during the Warranty Period, Residentia Group shall, at its discretion, determine whether repair, replacement or refund will apply if an Appliance has a valid warranty claim applicable to it.
12. Missing parts are not covered by warranty. Residentia Group reserves the right to assess each request for missing parts in a case by case basis. Any parts that are not reported missing in the first week after purchase will not provide free of charge.
13. To enquire about claiming under this warranty, please follow these steps:
 - (a) carefully check the operating instructions, user manual and the terms of this warranty;
 - (b) have the model and serial number of the Appliance available;
 - (c) have the proof of purchase (e.g. an invoice) available;
 - (d) telephone the numbers shown below.
14. You accept that if you make a warranty claim, Residentia Group and its ASR may exchange information in relation to you to enable Residentia Group to meet its obligations under this warranty.

IMPORTANT

Before calling for service, please ensure that the steps in point 12 have been followed.

Telephone contacts

- ▶ Service: Please call 1300 11 HELP (4357)
- ▶ Spare Parts: Please call 1300 11 SPARE (7727)

The Australian Consumer Law requires the inclusion of the following statement with this warranty:

Our goods come with guarantees that cannot be excluded under the Australian Consumer Law. You are entitled to a replacement or refund for a major failure and for compensation for any other reasonably foreseeable loss or damage. You are also entitled to have the goods repaired or replaced if the goods fail to be of acceptable quality and the failure does not amount to a major failure.

A HIGHER LEVEL

INALTO?

OF COOKING

WWW.INALTO.HOUSE



E2447