

INALTO | CLASSIQUE

Curved Glass Rangehood 60cm



MODEL. ERBC60

FEATURES

- 3 speed settings
- 2 × LED lights
- 2 × Aluminium grease filters
- Push button controls
- Stainless steel body

PERFORMANCE FEATURES

750 m³/hr extraction

ACCESSORIES

- Expandable 150mm ducting adapter
- 2 × piece stainless steel flue
 - upper and lower pieces
- Fasteners and wall plugs
- Wall brackets

OPTIONAL ACCESSORIES

- Carbon Filter - CP506B
- Flue extension piece - RFE7

CLEANING

Dishwasher safe aluminium grease filter

EAN

9349260002562

PRODUCT DIMENSIONS

Packaged (w, d, h mm):
640 × 383 × 540mm
Physical (w, d, h mm):
595 × 500 × 533–1013mm
Weight (net/gross):
16kg/13.25kg

REQUIREMENTS

Supplied with 10 amp plug
Rated Voltage:
220-240V, 50/60Hz

WARRANTY

2 years

INSTALLATION

See below diagram

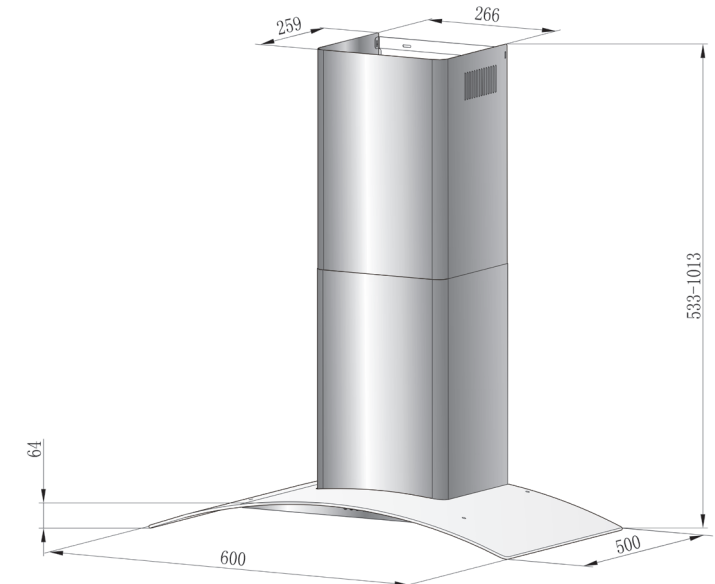

INALTO.HOUSE/CLASSIQUE