

USER MANUAL

INALTO?

INALTO.HOUSE

90cm Freestanding Cooker with Induction Cooktop

MODEL CODE/S

IU9EIB



FOR ALL AUSTRALIAN HOMES

V1.2 0224

Welcome

Residentia Group Pty Ltd
ACN. 600 546 656
165 Barkly Avenue
Burnley, Victoria 3121
Australia

—
Applico Ltd
635 Great South Road
Penrose, Auckland 1061
New Zealand

—
InAlto
www.inalto.house
f /inalto.house
@ /inalto.house

Congratulations on purchasing your new Freestanding Cooker!

The InAlto brand is proudly distributed within Australia by Residentia Group Pty Ltd and within New Zealand by Applico Ltd.

Please refer to the warranty card at the rear of this manual for information regarding your product's parts and labour warranty, or visit online at:

- www.residentia.group
- www.applico.co.nz
- www.inalto.house

Both Residentia Group & Applico are customer obsessed and our Support Teams are there to ensure you get the most out of your appliance. Should you want to learn more about recommended usage, the various features of your appliance, and importantly taking care of the unit when cleaning, our Support Teams are here to help.

Telephone Contacts:

- AU: 1300 11 4357
- NZ: 0800 763 448

It is important that you read through the following use and care manual thoroughly to familiarise yourself with the installation and operation requirements of your appliance to ensure optimum performance.

Again, thank you for choosing an InAlto appliance and we look forward to being of service to you.

SCAN ME



Scan to Register your InAlto Appliance or go to:

- AU: www.inalto.house/registration
- NZ: www.inalto.house/nz/registration

By registering your product, you will receive advanced support, stay updated with the latest from InAlto and find out about new products and promotions.

Contents

<u>02</u>	<u>Welcome</u>
<u>04</u>	<u>Safety Information</u>
<u>06</u>	<u>Installation Instructions</u>
<u>10</u>	<u>Your Appliance</u>
<u>11</u>	<u>Cooktop Overview</u>
<u>12</u>	<u>Operating Your Cooktop</u>
<u>17</u>	<u>Cooktop Care & Cleaning</u>
<u>18</u>	<u>Cooktop Troubleshooting</u>
<u>20</u>	<u>Oven Overview</u>
<u>22</u>	<u>Operating Your Oven</u>
<u>25</u>	<u>Oven Care & Cleaning</u>
<u>27</u>	<u>Oven Troubleshooting</u>
<u>29</u>	<u>Technical Specifications</u>
<u>30</u>	<u>Your Receipt</u>
<u>31</u>	<u>Purchase Details</u>
<u>32</u>	<u>Warranty Information</u>

Customer Care

InAlto recommends the use of original spare parts. When contacting our customer service team, please ensure that you have the following information at hand (which can be found on your appliances' rating plate).

- Model Number
- Serial Number

Safety Instructions

Important Safety Instructions

This cooker must only be installed by a suitably licensed and qualified installer in accordance with the instructions provided. Incorrect installation may result in bodily harm, damage to property, and void the product's warranty.

- **NOTE:** When the oven is first switched on, it may give off an unpleasant smell. This is due to the bonding agent used for the insulating panels within the oven, and is completely normal. To remedy this fragrance, follow the instructions on page 22 'Before First Use'.
- Never drag or push the appliance once it is unpacked. The appliance should instead be lifted in to place in order to avoid damaging your floor.
- Do not stand or sit on the open oven door, nor on the appliance itself, as this may result in an accident, cause damage to the appliance and void your warranty.
- This appliance is intended for domestic use only, and must only be used for food preparation.
- Adults and children must not operate the appliance without supervision if they do not have the physical or mental ability, or if they lack the knowledge and experience required to operate the appliance correctly.
- Never allow children to play with the appliance. Do not allow children to go near the oven when it is operating, especially when the grill is on. Children must be kept a safe distance from the appliance at all times.
- This appliance can be used by children aged from 8 years and above and persons with reduced physical, sensory or mental capabilities or lack of experience and knowledge if they have been given supervision or instruction concerning use of the appliance in a safe way and understand the hazards involved. Children shall not play with the appliance. Cleaning and user maintenance shall not be made by children without supervision.
- The appliance and its accessible parts become hot during use. Care should be taken to avoid touching heating elements or placing objects by the cooktop. Never touch the cooktop, the oven cavity, or the oven steam outlets while in operation, as they may be hot. Always open the door carefully when the oven is in use, as hot steam or heat may escape.
- Never cook meals on the floor of the oven cavity. Do not leave the baking tray on the floor of the cavity, nor should you cover the floor with aluminium foil.
- Do not place cookware on the cavity floor, as this will cause uneven distribution of heat. The cooking times will no longer be correct, and the enamel will be damaged.
- Never pour the water directly into a hot oven, as this may damage the appliance or generate steam that is harmful.
- If the hob plates are in operation for a prolonged period of time, the space between them can also become hot.
- Please follow the manufacturer's instructions when using special cookware. Aluminium foil and plastic containers can melt and stick on hot burners.
- Never operate the cooktop when there is nothing on top. Do not heat empty pots or pans, as this will damage the pan's base. Do not allow saucepans to boil dry, in particular enamel and aluminium saucepans.
- The base of the cookware used for the cooktop must be clean, dry and flat, as uneven surfaces can affect the cooking process or damage the cooktop surface.
- Metallic objects such as knives, forks, spoons and lids should not be placed on the cooktop as they can get hot.
- Do not use a roasting dish that is so large it has to be heated using two burners, as this will cause too much heat to accumulate, damaging your appliance.
- Never leave or store flammable objects on the hob or in the oven, it is suggested to store cooking oils in a cupboard away from the appliance.
- Overheated oil or fat can ignite very quickly. Never leave fat or oil to cook unattended. Should the oil ignite, do not try and put it out by pouring water on it. Cover the pan immediately with a lid or plate, and switch off the cooktop. Allow the cookware to cool down on the cooktop before removing.
- Be careful with food that is prepared using drinks with a high alcohol content, such as wine, rum or cognac. Alcohol evaporates at high temperatures, and in some circumstances the alcoholic vapors can catch fire. Only use small quantities of drinks with a high alcohol content and open the appliance door carefully when doing so.
- After cooking, only leave the oven to cool down with the door closed. The fronts of adjacent units may eventually become damaged by the emitted heat, even if you only leave the door slightly open.
- Never trap the mains cable of electrical appliances in the appliance door or pull the cable over the hob plates when they are hot, as the cable insulation may melt.

-
- **WARNING:** Incorrect repairs are dangerous. Repairs may only be carried out by an authorised service technician or a similarly qualified individual.
 - **WARNING:** Never replace a damaged power cable yourself. Power cables may only be replaced by an authorised service technician or a similarly qualified individual. Switch off the circuit breaker in the fuse box if the appliance appears faulty, and contact our friendly after sales support team for further instructions.
 - Ensure that the appliance is switched off before replacing the oven lamp to avoid the possibility of electric shock.
 - If the door seal is very dirty, the appliance door will no longer close properly during operation. Always ensure you keep the seal clean.
 - Do not use harsh or abrasive cleaners or sharp metal scrapers to clean the oven door glass, as they may scratch the surface which can result in the glass shattering. Similarly, do not use steam cleaners.
 - The hob surface is made of toughened ceramic glass: if the surface is cracked, switch off the appliance to avoid the possibility of electric shock or further damage, and contact our after sales support team for guidance.
 - Ensure that this product is disposed of correctly, to prevent any possible damage to the environment and to human health which might otherwise be caused if the appliance were to be disposed of incorrectly.
 - This product may not be treated as normal household waste. It should be taken to a collection point for the recycling of electrical and electronic goods.
 - As this appliance requires a specialist waste disposal, for further information regarding the treatment, recovery and recycling of this product please contact your local council, your household waste disposal service or the store of purchase.
 - To disassemble and remove the appliance, perform the installation instructions in reverse order. Always perform disassembly with two people to avoid risk of injuries. Installation and disassembly must always be carried out by either an authorised service technician, or a similarly qualified person.
 - Materials used for packaging the appliance include those that are environmentally friendly and are 100% recyclable. Environmentally materials have been marked and can be identified with the appropriate symbol.
 - Ensure you remove all the packaging, taking care to discard waste responsibly.
 - Under no circumstances should you install or use a damaged appliance.
 - Always move the appliance carefully. Do not use the machine door or the handle of your oven when lifting or relocating the appliance.
 - The appliance must always be installed by an authorised technician or similarly qualified person. Please note that the manufacturer is not held responsible for any damage caused by defective placement or installation done by an unauthorised personnel.
 - To arrange an authorised technician please contact our friendly support team at 1300 11 HELP (4357).
 - **CAUTION:** The appliance must be earthed.
 - Ensure the information on the oven's rating plate agrees with the power supply. If not, contact an electrician.
 - Always use a correctly installed shockproof socket.
 - Do not use any multi-plug adapters or extension cables.
 - Connect the mains plug to the mains socket only at the end of the installation. Make sure that there is access to the mains plug after the installation. Do not connect the appliance plug with a power connection board.
 - Do not pull the mains cable to disconnect the appliance. Instead pull the plug portion of the mains cable.
 - Never touch the mains cable or plug with wet hands, nor should you touch the oven with wet hands or feet.
 - **WARNING:** If the supply cord is damaged, it must be replaced by the manufacturer or its service agent or similarly qualified person in order to avoid a hazard.
 - **WARNING:** All electrical work must be done in accordance with local and national electrical codes as applicable and should be undertaken by licensed and qualified persons only. Failure to follow these instructions can result in death, fire or electrical shock.
 - The manufacturer is not responsible if incorrect installation or use causes injuries and damages.
 - Before installing and using your appliance, carefully read the supplied instructions. Always keep the instructions with you for future reference.
 - Always wear appropriate clothing when operating the oven, such as clothes that cover your torso, legs and feet.

Installation Instructions

Prior to Beginning Installation

- Make sure to check the condition of the appliance after unpacking it. Do not continue with installation if it has been damaged during transport.
- Safe operation of this appliance can only be guaranteed if it has been professionally assembled and installed in accordance with these instructions by a qualified technician. The individual who assembled and installed the appliance is liable for damages or faults resulting from an incorrect assembly or installation.
- Installation and maintenance must be carried out by an authorised service agent or similarly qualified technician.
- Ensure power to the appliance has been shut off before carrying out any installation or maintenance.
- It is vital that the appliance is properly earthed before completing the installation process.
- If a rangehood is to be fitted, follow the installation guidelines supplied with the rangehood.

Fitting the Adjustable Feet

- Carefully remove all parts that are not permanently fixed, including the accessories stored within the oven cavity.
- In a team of at least two people, gently tilt the appliance by raising one side slightly from the floor.
- With the plates in position, screw the adjustable feet into the mounting holes found underneath the appliance. Repeat this process on each side.
- You can make the final adjustments to the feet in order to level the appliance once the gas and electricity supply have been connected.
- If it is necessary to pull the appliance, the feet must be screwed in fully beforehand. Make your final adjustments only when the remaining steps have been completed.

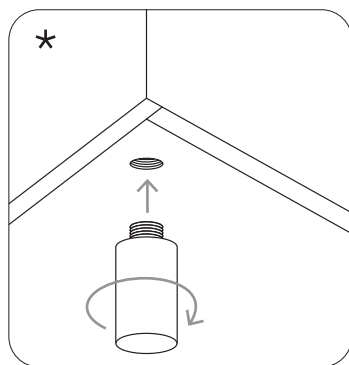
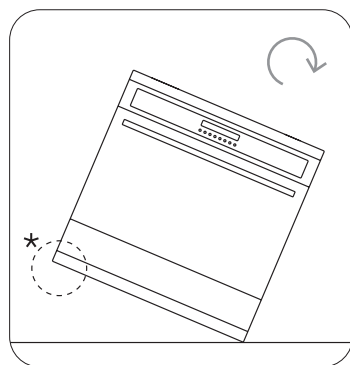

Fitting the Splash Back

- Remove the packaging and protective film from the splash back, taking care to dispose of the material safely and responsibly,
- Screw the splash back onto the rear of the appliance using the two supplied bolts, each with a washer, a retaining washer and a nut.

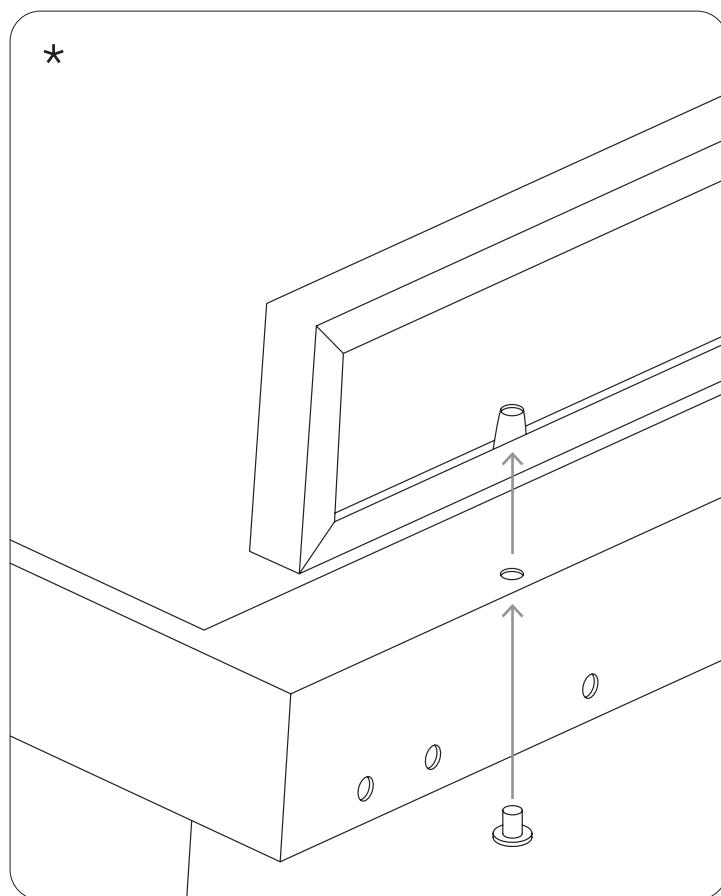
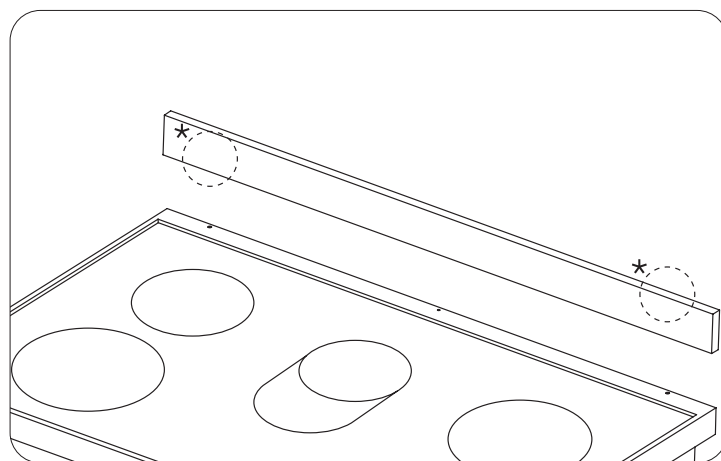

Positioning and Levelling

- When installing the appliance, ensure that there is enough space in the desired location to be able to pull the appliance forwards and backwards, as this is necessary when undergoing cleaning and maintenance.
- The ground underneath the appliance must be flat and stable. The wall immediately behind the appliance must be made from non-flammable materials, such as tiles.
- To level the appliance, turn the adjustable feet clockwise and anti-clockwise, carefully ensuring that the surface of the appliance is level. This step may only be undertaken once all other installation steps have been completed.

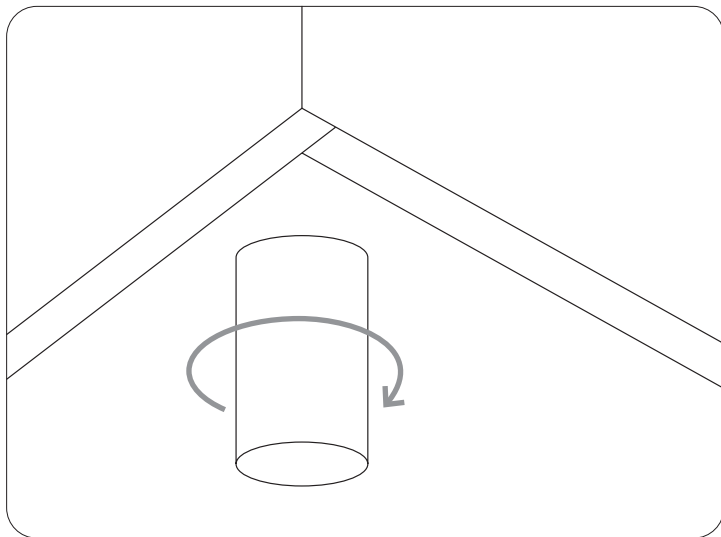

Electrical Connection Safety

- This appliance must be earthed by law. Before connecting the appliance to the electrical supply, it is necessary to check that your home's earthing system is working correctly.
- Check that the unit and voltage power marked on the appliance's rating plate are compatible with the supply. It is necessary that the feeding network is protected by a powerful switch able to disconnect the network completely, with a contact separation of at least 3mm. Ensure that the yellow-green earth wire is not interrupted by the switch.
- In order to avoid potential health hazards, any electrical work performed on this appliance or its associated wiring should only be done by an authorised service technician or a similarly qualified technician.

Mounting or Replacing the Power Cord

The mains cable is connected via the rear backboard. The mains cable must be of the following type:

380–415V 3N~		220–240V	
H05RR-F		H05RR-F	
H05VV-F	5 × 2.5mm ²	H05VV-F	3 × 4mm ²
H05RN-F		H05RN-F	
H07RN-F		H07RN-F	

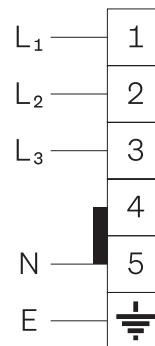

Leave the mains cable slightly long so that you can pull out the appliance for cleaning purposes.

Proceed as follows:

1. Gently remove the rear backboard.
2. Undo the screw on the terminal block that fixes the cable in place, taking care not to lose the screw.
3. Loosen the screw contacts and replace the cable with a new one of the same length. Note that the cable must comply with the stipulated specifications.
4. Connect the yellow-green wire to the  terminal. Note that the yellow-green wire must be at least 10mm longer than the other wires.
5. Connect the blue neutral wire to the N terminal.
6. Connect the brown power wire to the L terminal.

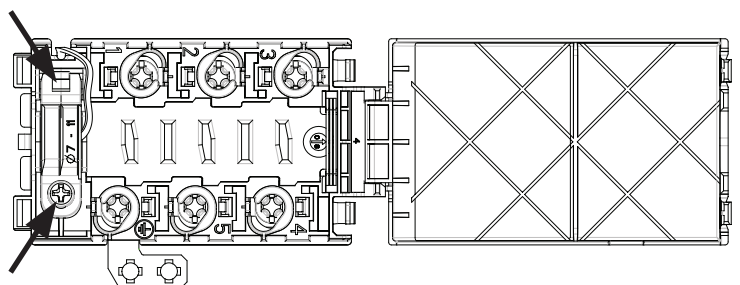

Installation Instructions (Continued)

Fixing the Stability Bracket

Mounting the bracket securely is vital for your appliance's stability. Ensure you align and level the bracket accurately before fastening, whilst using the appropriate tools. See the diagram below for a guide on fixing the stability bracket.

Need Help?

If you're feeling stuck and need any assistance, please speak to our Support Team by calling 1300 11 4357, or simply reach out by emailing support@residentiagroup.com.au

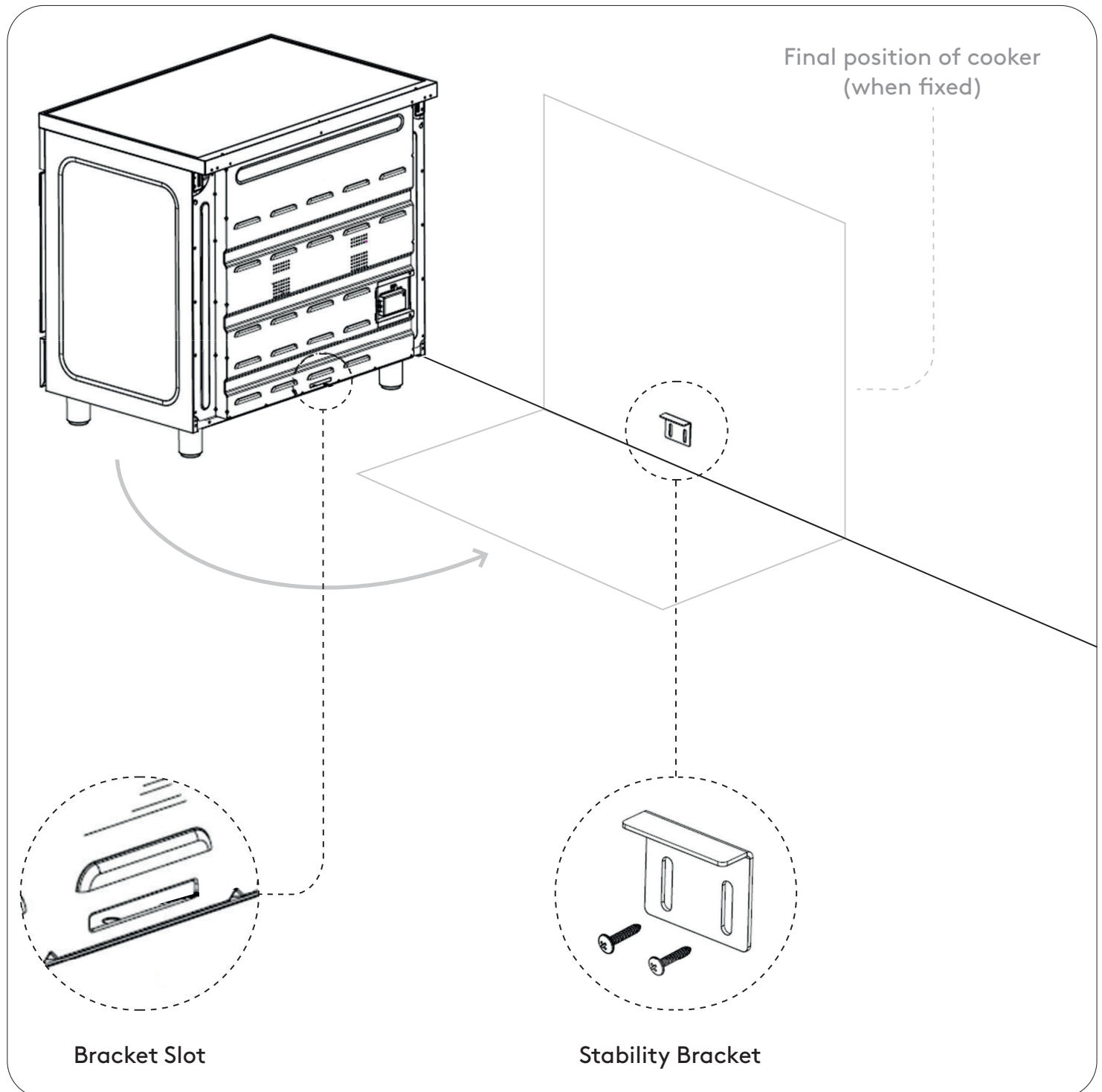

Built-In Installation Safety

IMPORTANT: Kitchen cabinets must be made of materials capable of withstanding temperatures at least 65°C above room temperature. This is necessary to avoid possible damage to the cabinets during oven usage over time.

IMPORTANT: When installing the unit as a built-in appliance, always secure it on a raised platform using suitable fastening systems. If you are installing the unit as a built-in appliance, **DO NOT** install the supplied adjustable feet with the unit.

Built-In Installation Diagram

113mm * = Minimum distance between cabinetry benchtop and splash back.

53mm † = Minimum distance between cabinetry benchtop and cooktop surface.

20mm ‡ = Minimum distance between cabinetry surface and cooker surface.

NOTE: Your appliance may appear differently. Images in this user manual are for reference only.

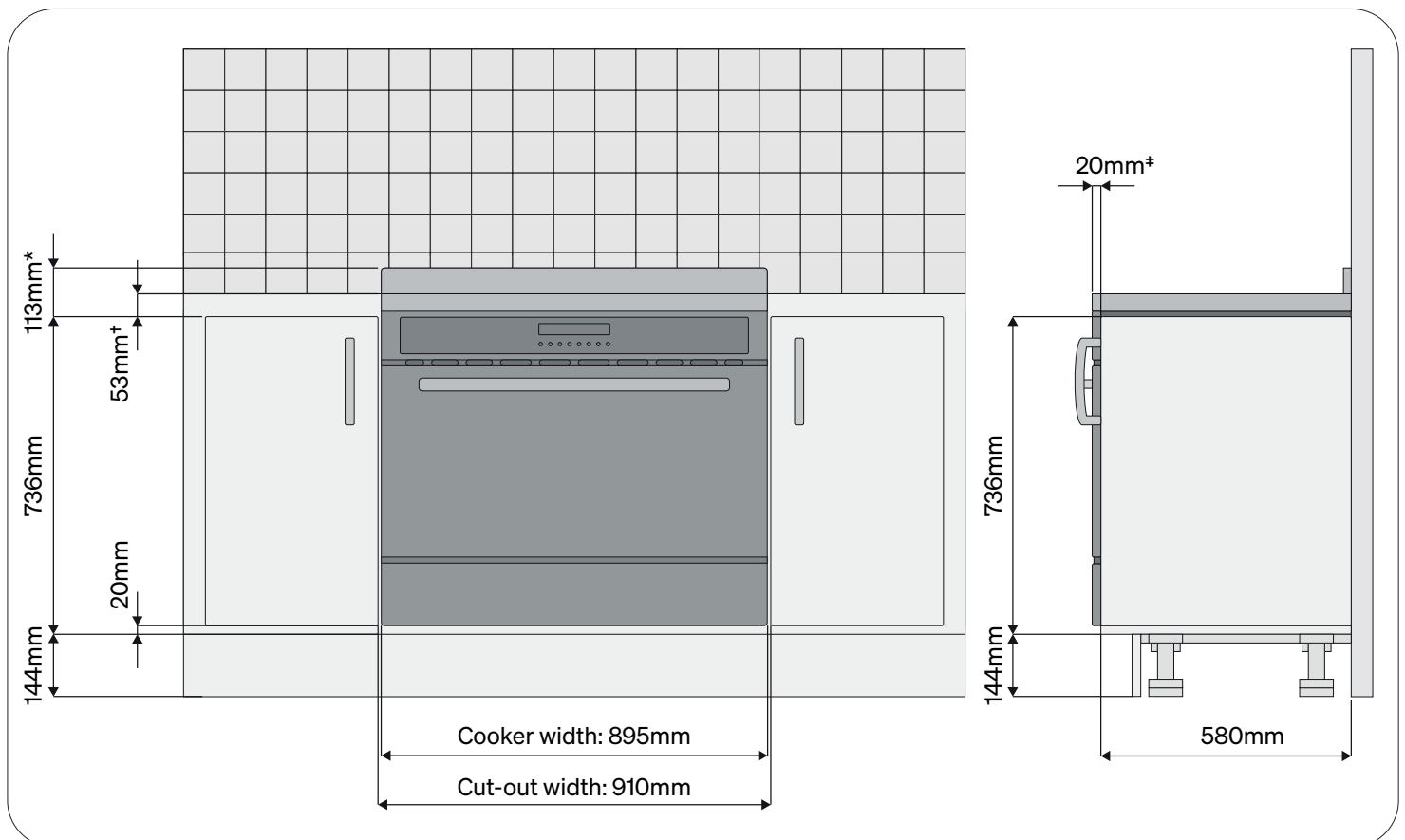

Your Appliance

Dimensions

Please use the specified dimensions as a guide. Note that images in this user manual are intended for reference only, your appliance may appear differently.

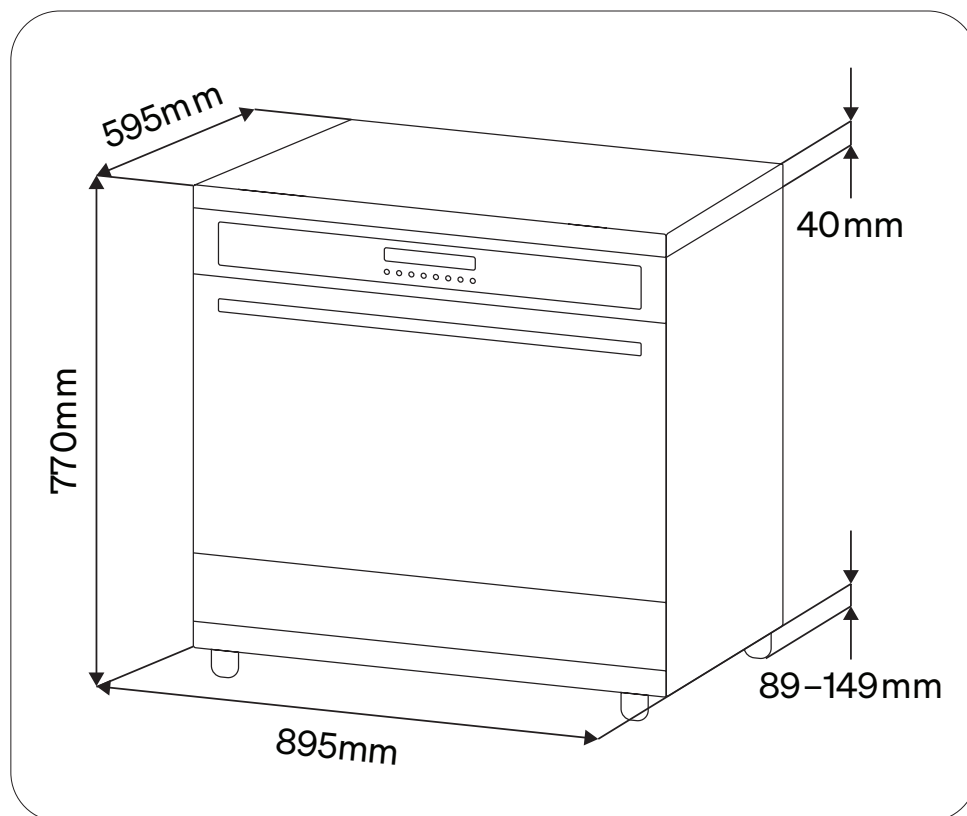

Surrounding Cabinetry

Cabinetry adjacent to the appliance must be made of non-combustible material. The front of the adjacent units must be able to resist temperatures up to 90 °C. If the appliance is fitted close to other units, it is integral that the minimum dimensions detailed in this diagram are followed.

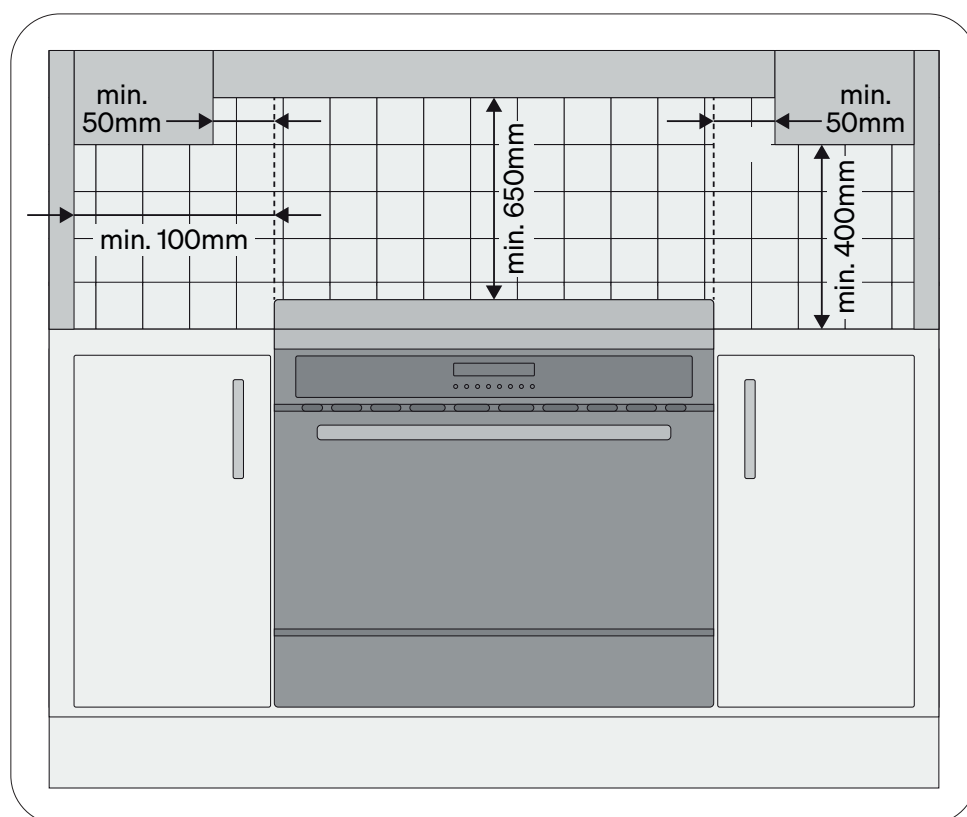

Cooktop Overview

Top View

Key

- | | | |
|---------------------------------|-------------------------------|-----------------------------|
| 1. 1800–3000W Zone
200×200mm | 3. 3000–4000W Zone
Ø 280mm | 5. Bridge Zone
400×200mm |
| 2. 1800–3000W Zone
200×200mm | 4. 1400–2000W Zone
Ø 280mm | 6. Zone Controls |

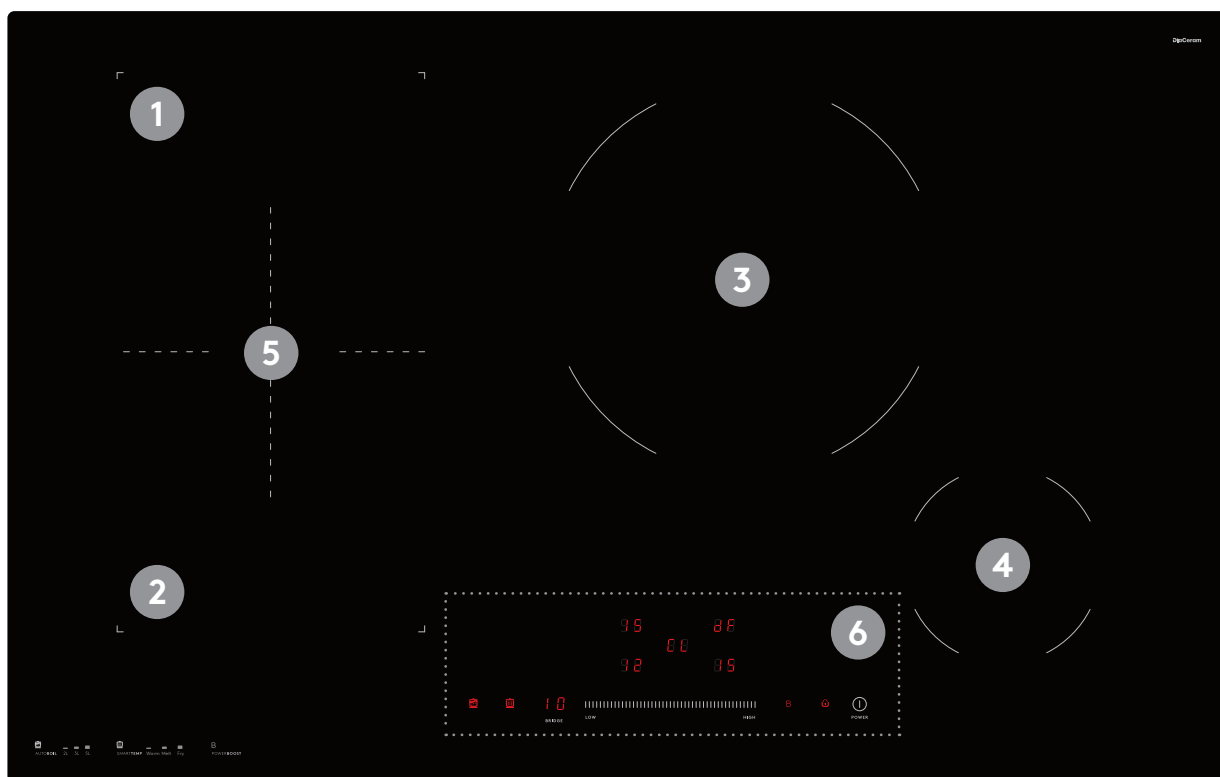

Controls

Key

- | | | |
|---------------------------|-----------------------|----------------------|
| 1. Cooking Zone Selection | 4. SmartTemp Function | 7. Boost Function |
| 2. Timer Function | 5. Bridge Function | 8. Child Safety Lock |
| 3. AutoBoil Function | 6. Temp/Time Slider | 9. Power Button |

NOTE: Further information on controls, their functions and purpose can be found on pages 13–16.

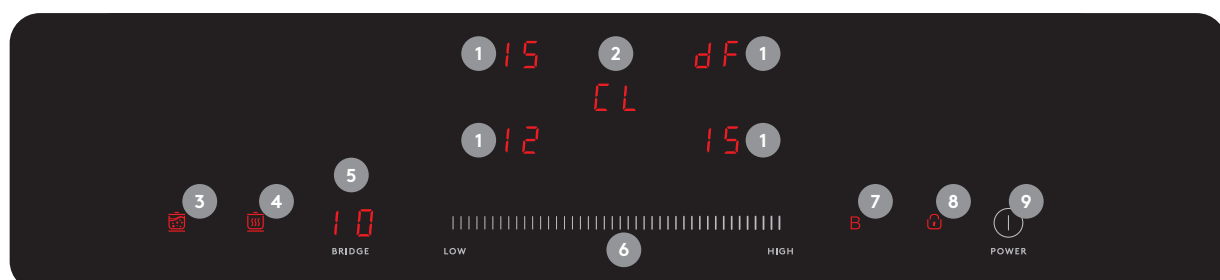

Operating Your Cooktop

Using the Touch Controls

- Read this user manual carefully, taking special note of the 'Safety Information' chapter in particular.
- Ensure you remove any protective film that may still be on your cooktop surface after unpacking.
- The controls respond to touch, so you don't need any pressure. Use the pad of your finger, not the tip.
- You will hear a beep each time a touch is registered.
- Make sure the controls are always clean, dry, and that there is no object (e.g. a utensil or a cloth) on top. Even a thin film of water or food particles may make the controls unresponsive and difficult to operate.

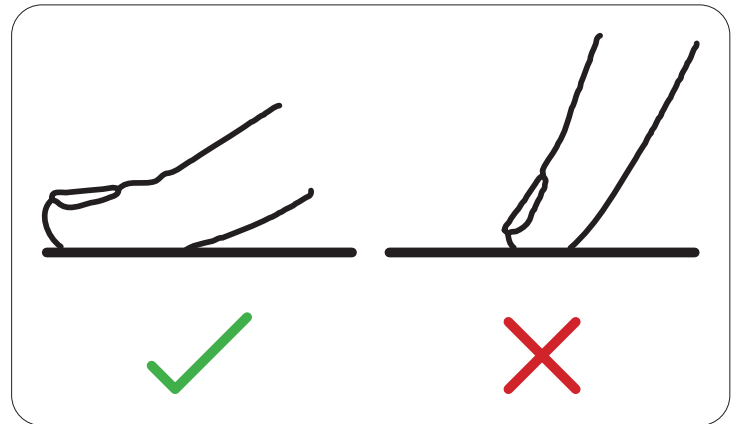

Choosing the Right Cookware

- Do not use cookware with jagged edges, coarse or uneven surfaces, chipped bottoms or a curved base.



- Make sure that the base of your pan is smooth, sits flat against the glass, and is the same size as the cooking zone. Always center your pan on the cooking zone.



- Always lift pans off the ceramic hob—do not slide them, as they may scratch the glass.



Touch the Power button to turn the cooktop on. The buzzer will sound once, the timer will show '00' and the Zone Selection controls will show '00' indicating that the induction cooktop has entered standby mode.

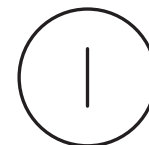

Place a suitable pan on the cooking zone you wish to use. Make sure the bottom of the pan and the surface of the cooktop are clean and dry.

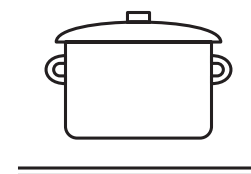

Within the Zone Selection controls, touching the desired cooking zone will cause an indicator will flash, indicating that you are now controlling that specific zone.



Adjust the zone's heat setting by using the sliding Temp/Time control. If you don't choose a heat setting within one minute, the cooktop will automatically switch off, and you will need to start again from the beginning. You can modify the heat settings at any time during cooking.



If the display flashes 'U' alternately with the heat setting, this could mean that:

- You have not placed your cookware on the correct cooking zone,
- The cookware you are using is not suitable for induction cooking,
- The cookware is too small or not properly centred on the zone.

Note: No heating will take place unless there is suitable cookware on the cooking zone. The display will automatically turn off after one minute if no suitable cookware is used.



When you have finished cooking, touch the cooking zone you had previously, then touch the Temp/Time slider moving towards the left until the display shows '0'. Alternatively you can turn the entire cooktop off by touching the Power button.



'H' will show on your display to indicate that the cooking zone is hot to touch. The cooktop will stop displaying 'H' once the surface has cooled down to a safe temperature, cool enough to touch.

Note: 'H' can also be used an energy saving function if you want to continue heating cookware using the zone that is still hot.

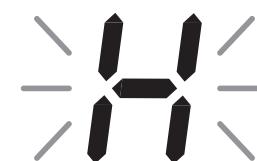

Operating Your Cooktop (Continued)

Using the Flexible Bridge Function

The Bridge zones within the cooktop are modular, and can be used either as a single larger zone, or two smaller zones independently, according to your needs.

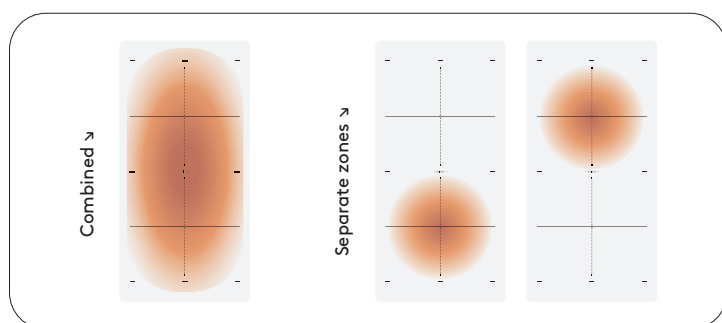

Examples of how to use the Bridge zone:

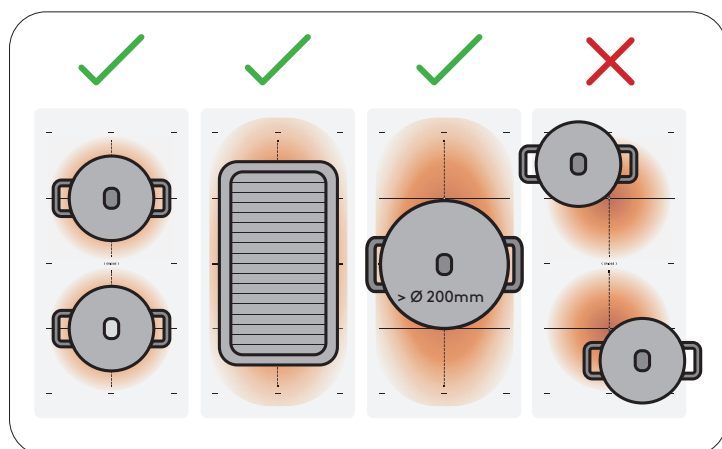

Activating the combined Bridge zone:

1. To activate the bridge area as a larger, combined zone, simply press the Bridge function button
2. The power settings will work the same as the other zones.
3. If cookware is moved from one end of the bridge zone to another, the cooktop will automatically detect where the cookware has been moved to, and maintain the same level of power for the new placement.
4. To add another pot to the Bridge zone, simply press the Bridge button again in order for the zone to detect the new piece of cookware.

Operating the Bridge zone as two independent zones:

To operate the flexible Bridge zone as two independent zones, simply press either of the two halves of the Bridge button. The half of the button will activate the bottom zone, while the half will activate the top zone.

Using the Boost Function

While a cooking zone is active, touch the button for that zone followed by the Boost button. The zone indicator will display 'b' and the heat will be set at maximum power.

Touching the boost control **B**, followed by the cooking zone will revert the zone to its previous setting. Alternatively, touching the Temp/Timer slider control will also revert the zone to its previous setting.

The Boost function can be applied to all cooking zones, note however that after 5 minutes of the Boost function being activated, the zone(s) will revert to their previous settings.

If the Boost function is applied to a particular zone, adjacent zones will be limited in their power unless also boosted.

If the initial setting prior to using the Boost function is 0, the zone will eventually revert to level 15 rather than 0.

Using the SmartTemp Function

The SmartTemp function is a handy set of built-in automatic temperatures that can help simplify the cooking process.

The settings include **Melt** for items like butter or chocolate; **Keep Warm** for dishes needing to remain hot if they are going to be eaten at a later time; or the **Fry** setting which is perfect for cooking vegetables, meat and eggs.

To activate the SmartTemp function:

1. First touch the button for the particular zone you would like to use.
2. Next, touch the SmartTemp button
3. Touching the SmartTemp button again, the display will then show , indicating that the SmartTemp level is set to the 'Keep Warm' heat.
4. Touching the SmartTemp button a third time, the display will show , indicating that the SmartTemp level has been set to 'Melt' heat.
5. Touching the SmartTemp button a fourth time, the display will show , indicating that the SmartTemp level has been set to 'Fry'.
5. To cancel the SmartTemp function, simply tap the button for the zone you have selected, or alternatively touch the Temp/Time slide control to revert to the previous setting.

Note: This function can be used on multiple cooking zones simultaneously. Be sure not to use a lid, as this could affect the cooking process. Additionally, cast-iron cookware is also not recommended.

Using the AutoBoil Function

The AutoBoil function is a set of built-in temperature settings that can help simplify boiling water, soups, broths and pasta.

Note: This function can only work in the third cooking zone.

To activate the AutoBoil function:

1. First touch the button for the particular zone you would like to use.
2. Touch the AutoBoil button . The display will show '2L', indicating that the AutoBoil level is set to the '2L' heat.
3. Touching the AutoBoil button again, the display will then show '3L', indicating that the AutoBoil level has been set to '3L' heat.
4. Touching the AutoBoil button a third time, the display will show '5L', indicating that the AutoBoil level is set to '5L'.
5. Touching the AutoBoil button a fourth time, the display will show '0', indicating that the AutoBoil level is cancelled. To cancel the AutoBoil function mid cooking, simply tap the button for the zone you have selected, or alternatively touch the Temp/Time slide control to revert to the previous setting.

Once the water has boiled, a series of tones will sound and the corresponding zone's indicator will flash. Simply press the AutoBoil button to turn off the alert. The heat setting for the zone will automatically revert to 9.

Use pans with a diameter that proportionately correspond to the size of the cooking zone. Do not use cast-iron cookware, and do not use a lid as the lid may affect the boiling process.

Note: The initial temperature of the water used in the pot when heating will affect the boiling process. It is ideal that it is room temperature, not too hot nor cold.

Note: While AutoBoil or Boost is activated for the third zone, the fourth cooking zone's power will be limited.

Activating the Child Safety Lock

It is possible to lock the cooktop controls to prevent any unintended use. When the controls are locked, all the controls will be disabled except for the Power button.

To lock the controls:

1. First touch the Child Lock button , the display will show 'L', indicating that the Child Safety Lock has been activated.
2. To unlock the cooktop, ensure that the cooktop is turned on. Next, touch and hold the Child Lock button for several seconds. The cooktop will then unlock.

Using the Timer Function

The Timer function can be used in two ways, either as a minute minder (kitchen timer), or as a way to automatically turn off cooking zones after a set period of time. The timer can be set up to 99 minutes.

Using the timer as a minute minder:

1. Touching the Timer button , the display will show '10'. The '0' will flash, indicating both the default time of 10 mins, and '0' is ready to be calibrated.
2. Set the time by using the Temp/Time slider controls, sliding right to add more time, and sliding left to subtract time. The '0' will change on the display.
3. Touch the Timer button, and the '1' will flash.
4. Set the time by using the Temp/Time slider controls, sliding right to add more time, and sliding left to subtract time. The '1' will change.
5. Let go of the Temp/Time slider controls, and the timer will be set. Once the set time schedule has elapsed, an alert tone will sound for 30 secs, and the display will flash '00' indicating the timer is finished.

Using the timer to shutdown cooking zones:

1. First touch the button for the particular zone you would like to apply the timer.
2. Follow steps 2-5 of 'Using the timer as a minute minder'.
3. When the cooking timer has finally elapsed, the corresponding cooking zone will switch off automatically. Other cooking zones will continue to operate as normal.

Note: A decimal '.' next to the particular zone's power level indicator will illuminate, indicating that zone has had the timer applied to it.

If the timer is set on more than one zone:

1. When the timer is set for several cooking zones at once, decimal indicators '.' on the relevant cooking zones will be active. The timer display will show the relevant countdown for the cooking zone that has been most recently selected, and that zone's decimal indicator will flash. Touching a zone's button will allow the timer display to show the corresponding countdown to your selection.
2. Once the countdown timer for a zone has elapsed, that same zone will automatically switch off. The timer display will then show the next remaining countdown, and the decimal indicator for the corresponding zone will flash.

Operating Your Cooktop (Continued)

Over-Temperature Protection

Your freestanding cooker contains an in-built temperature sensor that monitors the heat inside the cooktop. When an excessive build-up of temperature is monitored, the cooktop will automatically stop operation.

Automatic Pan Detection

When cookware is an unsuitable size or is non-magnetic (e.g. aluminium), or an extraneous item has been left on top, the cooktop will automatically go on standby within one minute. The internal fan will keep cooling down the cooktop for a further minute to avoid over-temperature issues.

Below is a list of materials used for cookware that are compatible with induction cooking:



- Cast-Iron
- Enamelled Cast Iron
- Stainless Steel

The following materials are incompatible with induction cooking, and are not recommended:



- Aluminium
- Copper
- Glass

The above materials are incompatible unless there is a magnetic layer on the bottom of the cookware. However it is possible to use a pan adapter such as an induction hob heat diffuser in order to use such incompatible cookware.

Auto-Shutdown Protection

Auto-Shutdown is a safety function designed to protect your cooktop. In the event that the cooktop is accidentally left running, the cooktop will automatically shutdown after a set period of time. Despite this automatic safety feature, it is still recommended to exercise awareness when cooking to avoid endangering yourself or your family.

Power Level:	Keep Warm	1-5	6-10	11-14	15
Shut Down:	2hr	8hr	4hr	2hr	1hr

When a pot has been removed from the cooktop, the zone will stop heating immediately, and will automatically switch itself off after two minutes.

Induction Cooking Guide

CAUTION: Take care when frying, as oils and fats can heat up quickly, particularly when heated by the Boost function. At extremely high temperatures oil and fat will ignite spontaneously, presenting a serious fire and safety risk.

General Cooking Tips & Tricks

- When liquids come to a boil, quickly reduce the temperature setting to avoid the liquid boiling over and out of the pot, or to avoid burning your food.
- Using a lid when cooking will reduce cooking times and save energy by retaining heat.
- Minimising the amount of liquid or fat can reduce cooking times, as the more liquid added increases the time required to heat the food sufficiently.
- It can be helpful to begin cooking on a high heat setting, and then reducing as the food has properly heated up, speeding up the cooking process.

A Guide to Your Induction Heat Settings

While the exact setting required by each dish is unique and depends on many factors, the table below is a set of helpful guidelines that clarify the best starting points for different types of dishes. As always, experimentation and testing will ensure you discover the best settings for your cooktop.

Setting	Cooking Method
1-2	<ul style="list-style-type: none"> • Delicate warming for small amounts of food such as lamb • Melting chocolate, butter, and foods that burn quickly • Gentle simmering and slow warming of stews and soups
3-5	<ul style="list-style-type: none"> • Reheating previously cooked food • Rapid simmering, such as soups or slow-cooked meat • Cooking rice Tip: use 1 ½ cup of water to every 1 cup of rice
6-11	<ul style="list-style-type: none"> • Cooking pancakes, dosa and crepes • Frying and scrambling eggs quickly • Frying flatbreads such as roti, naan, pita or focaccia
12-14	<ul style="list-style-type: none"> • Sautéing food such as mushrooms, garlic and onions • Cooking pasta Tip: add 2 tbsp. of salt per 4 quarts of water • Reducing sauces such as gravy, dahl or curries
15-Boost	<ul style="list-style-type: none"> • Stir-frying dishes, such as noodle and rice dishes • Searing meat, such as beef, poultry, pork and seafood • Bringing water, or soups to a rolling boil

Cooktop Care & Cleaning

Care and Cleaning Guide

Marks, Blemishes or Spots	Solution	Warning
<p>Everyday soiling on glass.</p> <p>(fingerprints, marks, stains left by food or non-sugary spillovers)</p>	<ol style="list-style-type: none"> 1. Switch the power to the cooktop off at the wall. 2. Apply a ceramic cooktop cleaner while the glass is still warm (but ensure it is not hot!) 3. Rinse and wipe dry with a clean cloth or paper towel. 4. Switch the power to the cooktop back on. 	<p>When the power to the cooktop is switched off, there will be no 'hot surface' indication but the cooking zone may still be hot! Take care.</p> <p>Heavy-duty scourers, some nylon scourers and harsh/abrasive cleaning agents may scratch the glass. Always read the label to check if your cleaner is suitable.</p> <p>Never leave cleaning residue on the cooktop as it may become a stain.</p>
<p>Boil-overs, melts, and hot sugary spills on the glass.</p>	<p>Remove these immediately with a fish slice, palette knife or scraper suitable for ceramic cooktops, but beware of hot cooktop surfaces:</p> <ol style="list-style-type: none"> 1. Switch the power to the cooktop off at the wall. 2. Hold the blade or utensil at a 30° angle and scrape the soiling or spill to a cool area of the cooktop. 3. Clean the soiling or spill up with a dish cloth or paper towel. 4. Follow steps 2 to 4 above. 	<p>Remove stains left by melts, sugary food or spillovers ASAP. If left to cool on the glass, they may be difficult to remove or even permanently damage the glass surface.</p> <p>Cut Hazard: When the safety cover is retracted, the blade in a scraper is razor-sharp. Use with extreme care and always store safely and out of reach of children.</p>
<p>Spillovers on the touch controls.</p>	<ol style="list-style-type: none"> 1. Switch the power to the cooktop off at the wall. 2. Soak up the spill 3. Wipe the touch control area with a clean and damp sponge or cloth. 4. Wipe the area completely dry with a paper towel. 5. Switch the power to the cooktop back on. 	<p>The cooktop may beep and turn itself off, and the touch controls may not function while there is liquid on them.</p> <p>Make sure you wipe the touch control area dry before turning the cooktop back on.</p>

Cooktop Troubleshooting

Cooktop Fault Codes & Solutions

Fault Code	Possible Cause	Solution
'F1' or 'F6'	The cooktop may have experienced a temperature sensor failure.	<ul style="list-style-type: none">● Take note of the fault code and please call our Support Team by dialling 1300 11 4357 or email at support@residentialgroup.com.au● To avoid any damage to the appliance, risk of bodily harm or property damage, do not attempt to carry out any repairs yourself, instead wait for a service agent.
'F9' or 'FA'	There has been a temperature sensor failure for the cooktop's IGBT (Insulated Gate Bipolar Transistor).	
'FC'	The connection between the display board and main board has failed.	
'E1' or 'E2'	The cooktop may be receiving an abnormal supply voltage.	<ul style="list-style-type: none">● Please ensure that the power supply is as recommended.
'E3' or 'E4'	The temperature sensor within the cooktop is experience higher than normal temperature levels.	<ul style="list-style-type: none">● Please allow the cooktop to fully cool down before restarting it.● However if the problem persists, please call our Support Team by dialling 1300 11 4357 or email at support@residentialgroup.com.au
'E5'	The IGBT temperature sensor within the cooktop is experience higher than normal temperature levels.	

Note: These fault codes will only appear if an abnormality or fault occurs. In such an occurrence, the cooktop will enter a protective state and display one of the relevant fault codes as listed above. Do not ignore these codes if they appear.

For Serious Faults:

- Some minor faults can be fixed by referring to the table on page 19, however if an emergency or serious fault occurs, immediately set all controls to their off positions and disconnect the power from the source.
- If a serious fault occurs, DO NOT attempt any repairs yourself, instead wait for a service agent to do so.
- For assistance or to organize an authorised service agent contact our After Sales Support by calling 1300 11 4357, or by emailing support@residentialgroup.com.au.

For Serious Faults:

- Please note that if a service agent is asked to attend whilst the product is under warranty and finds that the problem is not the result of an appliance fault, then you may be liable for the cost of the call out charge.
- The appliance must be accessible for the service agent to perform any necessary repair. If your appliance is installed in such a way that a service agent is concerned that damage will be caused to the appliance or your kitchen, then they will not complete a repair.
- Refer to the Warranty Information to learn more.

For Minor Faults

Problem	Possible Cause	Solution
The cooktop cannot be turned on.	No power is going to the cooktop.	<ul style="list-style-type: none"> ● Ensure the cooker is connected to the power, and is switched on. ● Check if there is a power outage in your home or area. If the problem persists contact our Support Team for guidance.
The touch controls won't respond, or are difficult to operate.	The controls may be locked, or there may be a slight film of water on the controls, or you may be using the tip of your finger as opposed to the pad when touching controls.	<ul style="list-style-type: none"> ● Unlock the controls, see page 15. ● Make sure the touch controls are properly dry, and to use the pad of your finger rather than the tip.
The cooktop has been scratched.	Rough-edged cookware, or unsuitable cleaning products such as an abrasive scourer may have been used on the cooktop.	<ul style="list-style-type: none"> ● Use cookware with flat and smooth bases. See page 12.
Some of my cookware makes crackling or clicking noises.	This may be caused by the construction of your cookware, as different layers of metals vibrate.	<ul style="list-style-type: none"> ● This is normal for cookware to make these noises, and does not indicate a fault.
There is a low humming noise when using high heat settings.	This is caused by the electronic technology of induction cooking.	<ul style="list-style-type: none"> ● This is normal, the noise will lessen for lower heat settings.
There is a fan noise coming from beneath the cooktop.	A cooling fan built into your cooktop has activated to prevent the electronics from overheating.	<ul style="list-style-type: none"> ● This is normal, however it is important that you don't shut the power off while the fan is running.
Cookware does not become hot and the display shows the 'E' symbol.	The cooktop cannot detect the pan either because it is not suitable for induction cooking, or it is too small for the zone it has been placed on.	<ul style="list-style-type: none"> ● Use cookware suitable for induction cooking, see page 16. ● Use the right size pan for zones.
The cooktop, or one of the zones has turned off unexpectedly, and a tone is sounding alongside an error code on the display.	This may be the result of a technical fault. To identify the fault code and its meaning, read the table on Fault Codes found on page 18.	<ul style="list-style-type: none"> ● Please note down the error letters and numbers, switch off the power from the wall and contact our Support Team by dialling 1300 11 4357 or by emailing us at support@residentiagroup.com.au

Oven Overview

Front View

Key

- | | | |
|--------------------------------|--------------------------------|--------------------------------|
| 1. Digital Touch Control Panel | 4. Induction Cooktop | 7. Adjustable Feet (Removable) |
| 2. Aluminium Handle | 5. Stainless Steel Splash Back | |
| 3. Cool-Touch Door | 6. Storage Compartment | |



Controls

Key

- | | | |
|-------------------|-----------------------|-----------------------------|
| 1. LED Display | 4. Oven Function Mode | 7. Temperature/Cooking Time |
| 2. Clock Function | 5. Menu Adjust — | 8. Pause /Stop |
| 3. Kitchen Timer | 6. Menu Adjust + | 9. Start /Select |

Note: Further information on controls, their functions and purpose can be found on pages 22-23.

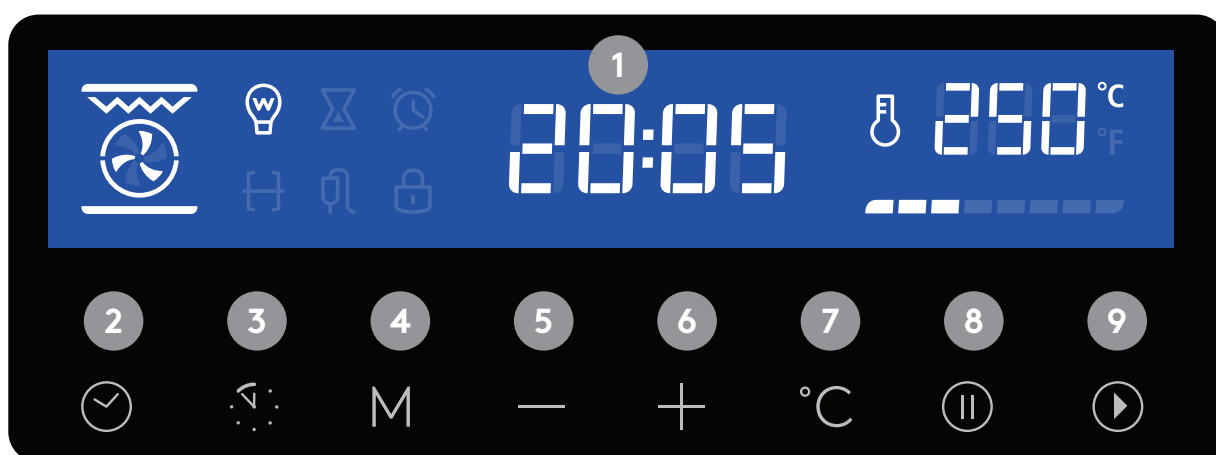

Accessories

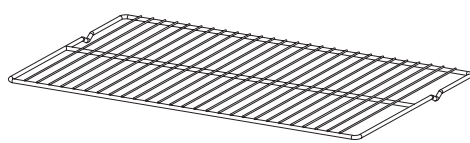
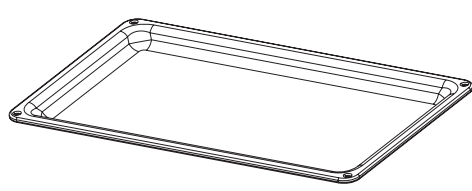
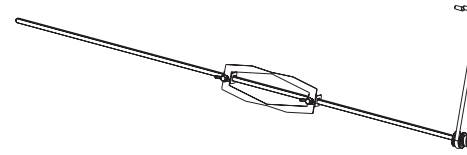
		
<p>Chrome Safety Shelves</p> <p>Chrome wire baking and roasting shelf, used to house ovenware such as cake tins, trays, etc. Commonly used for roasts, grilling, cooking frozen meals, pizza, etc. Handwashing recommended.</p>	<p>Enamelled Baking Tray</p> <p>For moist cakes, pastries, frozen meals and large roasts. The tray can also be inserted underneath the wire rack or used with the rotisserie to be used as a drip tray to collect fat and oil. Handwashing recommended.</p>	<p>Rotisserie (Rotary Spit)</p> <p>The rotisserie is used for roasts and large pieces of poultry. Use only in combination with the enameled baking tray, to avoid damaging your appliance or creating hard to clean mess. Handwashing recommended.</p>

Operating Your Oven

Before First Use

Before using your new Freestanding Cooker for the first time, please read this manual thoroughly, even if you are familiar with this type of appliance. Pay particular attention to the chapters 'Safety Information', 'Installation Instructions' and operating instructions for both the cooktop and oven.

After the appliance has been properly installed, and before first use, you should burn off any dust, oil or other remnants that may have been left inside the cavity from the manufacturing process. Run the empty oven with the conventional cooking function at 250°C for 90 minutes.

Your Oven's Functions

Light

The internal halogen lamp illuminates the oven cavity, allowing for safe observation of the cooking process. This is ideal for when you are finished using a cooking program, but wish to leave the dish inside the oven to cook further with residual heat. Note the lamp is active for all oven functions.

Defrost

The defrost function uses a fan to circulate room temperature air throughout the oven cavity. This allows for quick, gentle and thorough thawing of frozen food without the use of heating elements that might otherwise unevenly cook or burn the surface of frozen foods.

Lower Element

Range: 60–120°C. Heat concentrates from the bottom element only. Note the fan will not be activated. This function is ideal for food such as pastries, pizzas or lasagne that require a particularly crispy base, but also require their top surface to be gently cooked.

Bake (also known as Conventional)

Range: 50–250°C. Both top and bottom elements work together to provide an even heating of food. Ideal for cooking baked goods such as breads, cakes or cookies as well as egg-based dishes such as quiche or custards. As always, preheat your oven to the set temperature for best results.

Fan Bake

Range: 50–250°C. Fan forced air combined with the top and bottom elements distribute heat quickly and evenly, saving energy. Suitable for dishes placed on two shelves that require a short cooking time, such as pastries, cakes and biscuits; set at a low temperature to dehydrate.

Grill*

Range: 180–240°C. Heat radiates from the top element of the oven only. Ideal for browning the tops of dishes, such as tender cuts of meat, melts and toast. All of the grill functions are designed to pair well with the rotisserie accessory. Preheating the oven for 25 minutes allows for the best results.

Full Grill*

Range: 180–240°C. Both the inner radiant and top grill elements provide evenly distributed heat. Used for cooking, browning or caramelising food such as steaks, vegetables, toasties and casserole dishes for a cooked centre and crispy surface. Preheat your oven for 25 minutes for best results.

Full Grill & Fan*

Range: 180–240°C. Fan forced air with both of the grill elements distributes heat quickly and evenly, saving energy. Cooks, browns and caramelises larger amounts of food quickly and evenly, and works best with meat, vegetable and casserole dishes. Preheat for 25 minutes for best results.

Fan-Forced (also known as Convection)

Range: 50–240°C. A fan element circulates air quickly, distributing heat evenly within the oven cavity. This function is suitable for large family dinners such as roasts, vegetables or other types of food which require a tender, juicy inside and crispy, caramelised outside.



Using the Grill

The grill is situated in the top of the oven compartment. The grill pan should be located on the top oven shelf position. Always grill with the door closed.

WARNING: Do not place fatty foods too close to the grill and never leave the grill unattended. Fatty foods can cause the grill element to smoke. Leave the grill element on until the smoking has stopped then use as normal. If a grease fire should occur in a pan put out the flame by placing a lid on the pan. Do not throw water on a grease fire.





Setting the Time for Your Oven's Clock

Your oven's clock works in 24hr time as opposed to 12hr. After powering on, if the clock has not been set, the clock will then show '0:00' by default. If the time has not been set, simply power the oven off and on again, and repeat the instructions below:



1. Begin by connecting power to the unit, the oven display will then show '0:00'.
2. Next, press the Clock button , and the hour figures will flash, indicating they are ready to be set.
3. Press either the – or + buttons to adjust the hour figures between 0–23 hours.
4. After setting the hour, press the Clock button  again and the minute figures will flash.
5. Press either the – or + buttons to adjust the minute figures between 0–59 minutes.
6. Finally, press the Clock button  to finalise your time settings, ':' will flash and the time will be set.

Note: A tone will sound each time you have pressed a button. If a button is pressed inadequately, a tone will not sound.







How to Use Your Oven

1. Press the Function Mode button **M** cycle through the available oven functions, (as described on page 22).
2. Next press either the – or + buttons to adjust the cooking time. If skipped, the default time is 9 hours.
3. To adjust the temperature, press the °C button and use the – or + buttons to set the temperature.
4. Press the Start button  to begin the cooking program.
5. The cooking time can be adjusted at any point during cooking. Simply press the – or + buttons to select the new time, followed by the Start button  to confirm.
6. Similarly, the temperature can be adjusted at any point during cooking. To do so, press the °C button, followed by the – or + buttons to adjust the temperature, then press the Start button  to confirm.
7. To pause the program at any time, press the Pause button  and the oven will go to standby. Pressing  a second time will cancel the program completely.
8. An alarm will sound 5 times to remind you that the cooking program has completed.

Accessing the Clock During Cooking





1. At any point during the cooking process, provided the clock has been set, simply press  to check the current time.
2. If the Timer function has been activated and you wish to check the time, you can do so by via the  button.

Using the Oven Child Safety Lock

1. To activate the Child Safety Lock function, Press both the Start  and Pause  buttons simultaneously for three seconds. A tone will sound and the  symbol on the display will show indicating that the lock has been set.
2. To unlock, press the Start  and Pause  buttons simultaneously for 3 seconds once more. A tone will sound and the  symbol on the display will disappear, indicating the child lock function has been disabled.

Setting the Kitchen Timer

Your oven has a built-in Kitchen Timer function that can be a helpful reminder during the cooking process. The timer's alarm period can span from 1 minute through to 9 hours. The kitchen timer can only be set in standby mode.

1. Begin by pressing the Kitchen Timer button , the display will show both 'AL' and the  symbol.
2. Press the – or + buttons to adjust the alarm time.
3. Press Start  to confirm your setting, the ':' will flash on the display and the  indicator will light. The time will then begin to count down.
4. The timer can be cancelled at any time by pressing the Pause button  twice.
5. After the set time has elapsed, an alarm will sound ten times before the timer disables itself, however the oven will continue to cook.

Enabling the Oven Sleep Mode

1. During standby mode, press Start  for three seconds to put the oven display to sleep. This helps save power, particularly during the night or long periods of time when the oven will not be in use.
2. If the oven is in standby and has not been touched for ten minutes, the display will automatically enter sleep mode.
3. If you wish to exit sleep mode, press any button.

Operating Your Oven (Continued)

Rotisserie Safety

The rotisserie accessory can be used to cook joints such as poultry, prime rib or pork, with unique and excellent results. Using the rotisserie allows for meat to be cooked thoroughly and evenly with a caramelised surface.

WARNING: Never touch the hot surfaces of the oven cavity, and always wear protective gloves when using the rotisserie. Children must always be kept at a safe distance from the oven at all times, especially when grilling. Always open the oven door carefully, as hot steam may escape.

Note: The rotisserie tool can only be combined with the apt grill functions; namely 'Grill', 'Full Grill' and 'Full Grill & Fan'.

Preparing Joints for Your Rotisserie

Centre the joint onto the rotisserie rod as much as possible, and secure the meat at both ends using the retaining clips.

You can also truss the joint with string. Particularly in the case of poultry, where binding the wings and thighs against the body can prevent uneven cooking. Piercing the skin on the underside of a poultry joint's wings will allow fat to escape and collected by the grill tray.

Using Your Rotisserie

1. Prior to preheating the oven, insert the rotisserie hook into the bracket on the oven cavity's ceiling.
2. Once the oven has finished preheating, the rotisserie is ready to be placed. Always ensure you are wearing protective gloves during the process.
3. To attach the rotisserie, slide one end into the recessed slot on the left wall of the cavity.
4. Next, place the other end of the rotisserie rod onto the rotisserie hook on the right side of the cavity.
5. Gently insert the baking tray with a small amount of water into the lowest shelf position. This will safely collect any oil or fat run-off.
6. Once cooking has completed, carefully open the oven door, allowing steam to escape before removing the rotisserie from the hook and wall slot. Carefully remove the baking tray, taking care not to spill the water.
7. Once the oven has completely cooled down, simply remove the rotisserie hook attached to the ceiling bracket; wiping down surfaces with a soft, damp cloth.

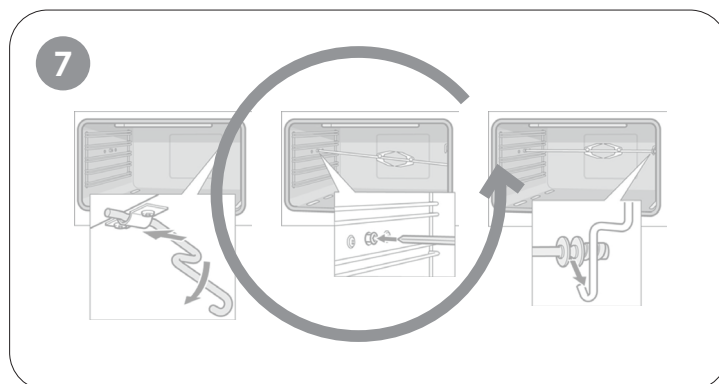
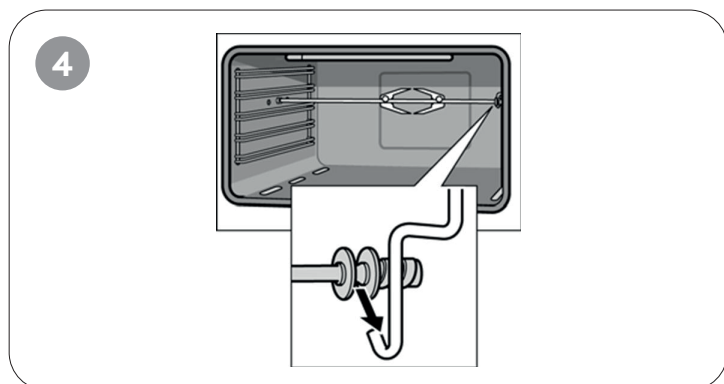
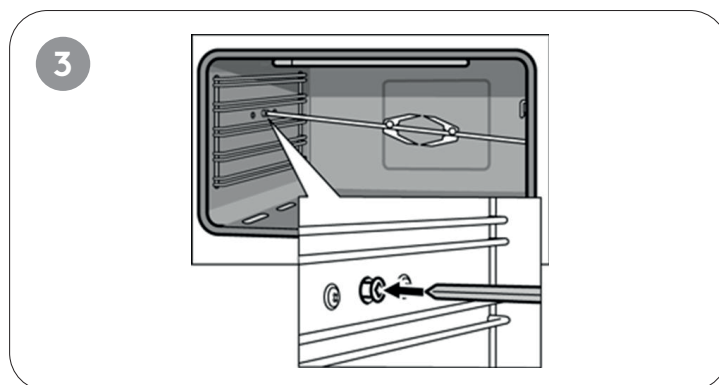
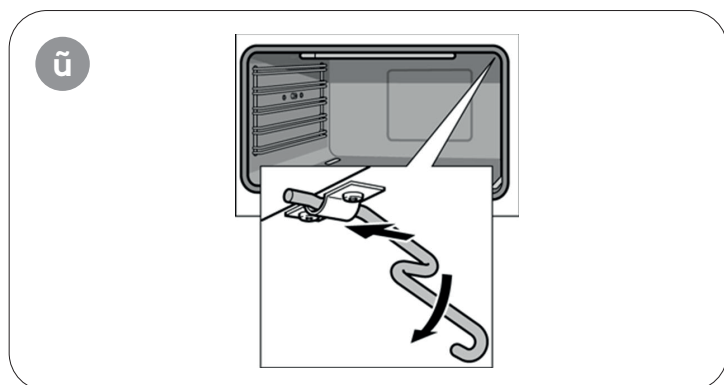

Oven Care & Cleaning

Prior to Cleaning Your Oven

- Before any maintenance or cleaning, ensure you have turned off the appliance and disconnected the power.
- Set all controls in their respective off positions.
- Wait until the inside is not hot but only warm –cleaning is easier than when the cavity is warm.
- The catalytic oven interior is coated with a self-cleaning enamel, enabling the oven to clean itself during operation.
- Most blemishes will be removed via the cooking process itself, however a soft cloth can be used to remove stains.
- Never use an oven cleaner for the inner cavity, instead use a lightly dampened cloth followed by a soft, fully dry cloth.
- For cleaning the oven door glass, do not use abrasive cleaners or sharp metal scrapers, as these can scratch the surface or lead to the glass being damaged.
- Never leave acidic substances such as lemon juice or vinegar on stainless steel, as this causes discolouration.
- Do not clean using a high pressure cleaner
- The baking tray and wire shelving may be handwashed using a mild detergent, and immediately dried afterwards.

Bulb Replacement

WARNING: Ensure that the appliance is switched off before replacing the lamp to avoid the possibility of electric shock.

1. Disconnect power from the mains outlet or switch off the circuit breaker of the unit's mains outlet.
2. Unscrew the glass lamp cover by turning it anti-clockwise (note, it may be stiff) and replace the bulb with a new one of the same type*.
3. Carefully screw the glass lamp cover back in place.

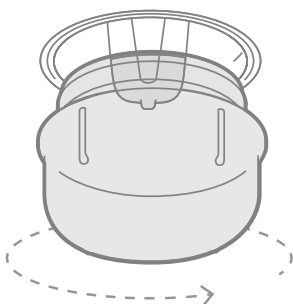

25W / 230V, G9, T300°C



Removing the Oven Door & Inner Glass

WARNING: Ensure that the appliance is turned off and the oven has completely cooled down before beginning this process. Ensure you have removed all shelves and trays.

Note: The catalytic oven interior is coated with a self-cleaning enamel, enabling the oven to clean itself during operation. Most blemishes will be removed via the cooking process itself, however a soft cloth can be used to remove stains. Never use an oven cleaner for the inner cavity, instead use a lightly dampened cloth followed by a soft, dry cloth.

Your oven has removable hook-in racks that can be removed to make cleaning the cavity easier.

To remove the oven racks, follow these instructions:

1. Undo the screw on the bottom of the rack. The lower hooks of the rack will then be released.
2. Take hold of the top of the rack and lifting upwards, unhook it from the holes in the side panel.
3. Follow these instructions in reverse order to refit the racks.

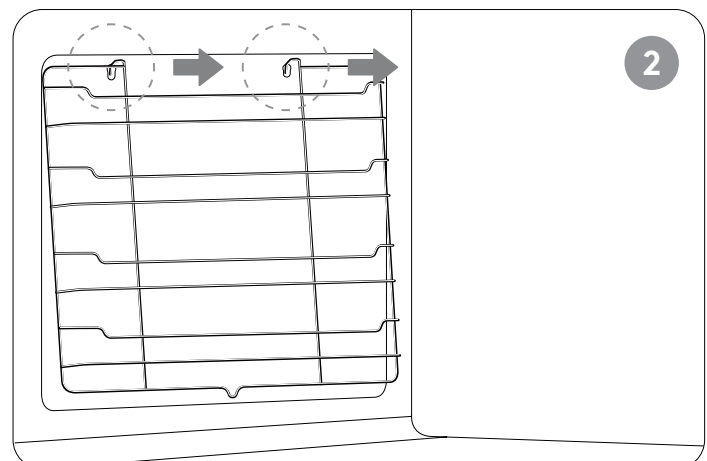
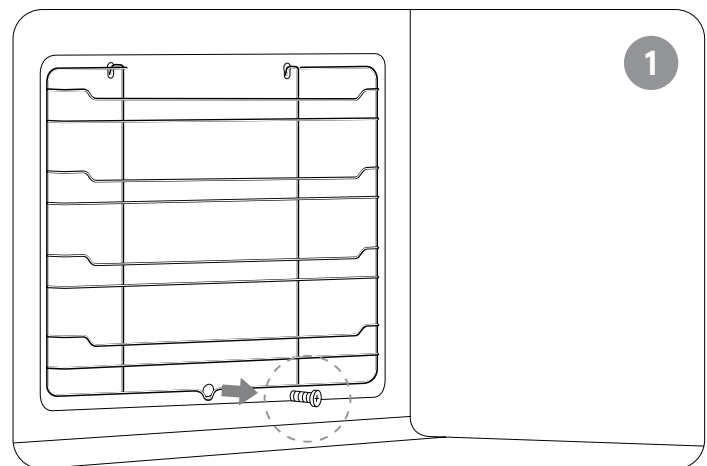

Oven Care & Cleaning (Continued)

Removing the Inner Glass

Follow the instructions and corresponding diagrams below carefully in order to remove the oven door's glass:

1. Begin by opening the oven door to the maximum opening angle.
2. Then pull the buckle (A) of the door hinges backward.
3. Slowly close the oven door until the door buckles (A), reach the slots of the oven door (B), locking them in place.
4. With the door opened 15°, unscrew (D) and (E) using a screwdriver, and gently remove the profile (F).
5. Remove the glass by pulling outwards, in the interim place the glass on a soft cloth to avoid scratches.
6. To refit, reverse the above procedures to return the door to its original position. Always ensure the door has been properly re-fitted before continuing to operate your oven.

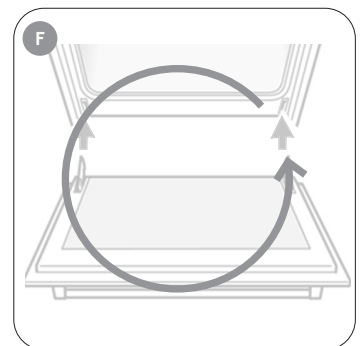
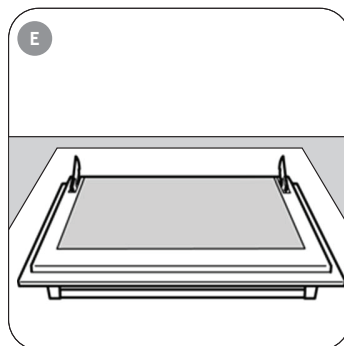
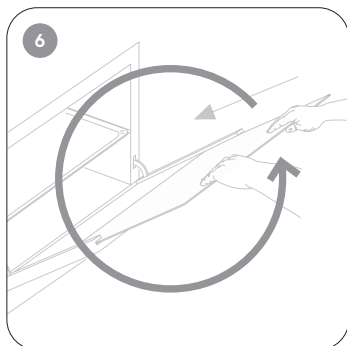
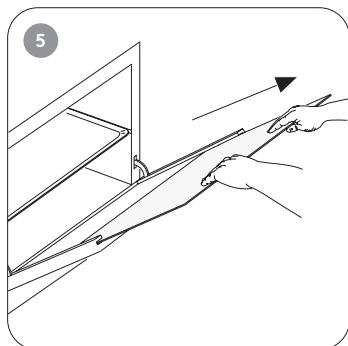
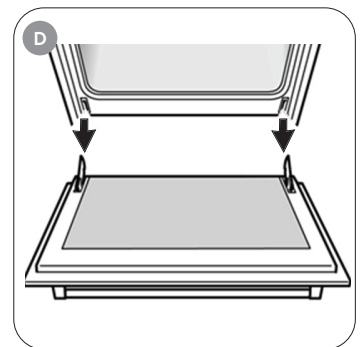
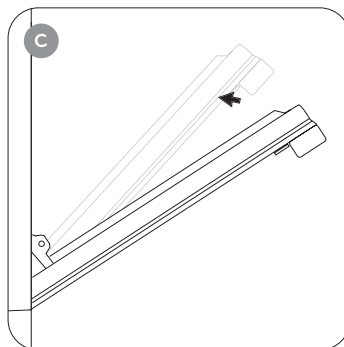
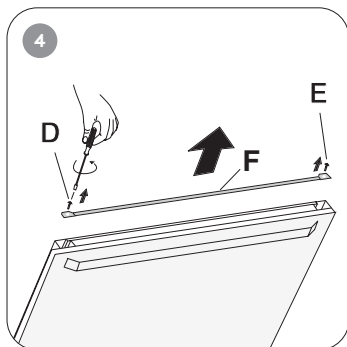
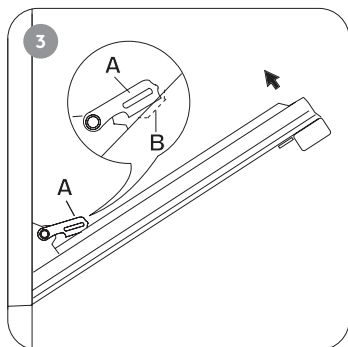
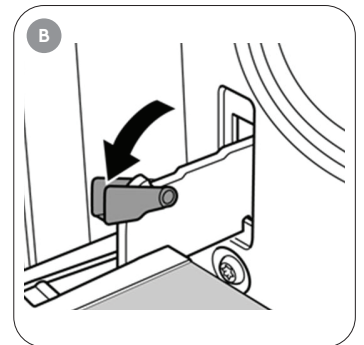
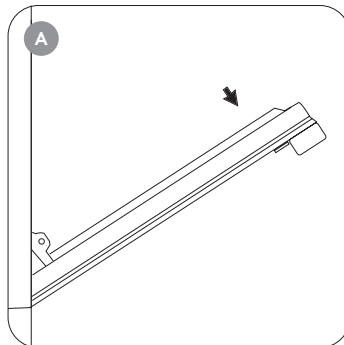
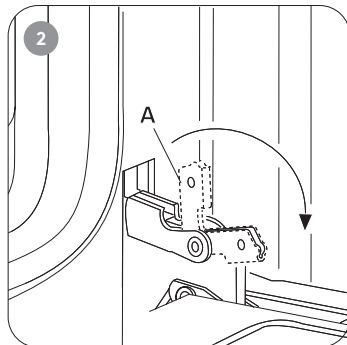
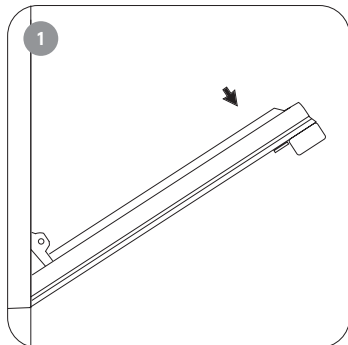

Removing the Oven Door

Follow the instructions and corresponding diagrams below carefully in order to remove the oven door:

- A. Open the oven door to the maximum angle.
- B. Then lift up the locking buckles on either side of the door.
- C. Slowly close the oven door at an angle of 15°, firmly holding the door on either side using both hands.
- D. Continue to close the oven door slightly, before lifting the door upwards at an angle to remove it.
- E. Ensure you place the door on a soft cloth in the interim to avoid any scratches.
- F. To refit, reverse the above procedures to return the door to its original position. Always ensure the door has been properly re-fitted before continuing to operate your oven.

Oven Troubleshooting

For Minor Faults

Problem	Possible Cause	Solution
The oven is not turning on, or has shut off suddenly while cooking.	A break may have occurred in the oven's power supply.	<ul style="list-style-type: none">● Check the household fuse box for blown fuses and replace as necessary. Ensure that a safety switch hasn't tripped.
The oven light has stopped working.	The light globe may have become loose or has blown.	<ul style="list-style-type: none">● When the oven has cooled and is switched off, remove the globe cover and ensure that the globe is tightly secured.● If blown, refer to page 25 under the Bulb Replacement section.
The oven burned the top of my dish, however the bottom is under-done.	Not enough heat is emitting from the bottom of the oven cavity.	<ul style="list-style-type: none">● Try the Conventional function.● Try lowering the temperature.● Try using a lower shelf position.
The oven burned the bottom of my dish, yet the top is under cooked.	Excessive heat is emitting from the bottom of the oven cavity.	<ul style="list-style-type: none">● Try the Conventional function.● Try lowering the temperature.● Try using a higher shelf position.
The oven burned the outside of my dish whilst the inside is under-done.	The temperature is set too high.	<ul style="list-style-type: none">● Lower the oven temperature and increase the cooking duration.
The outside of my dish is too dry, even though it looks like it's cooked.	The temperature is set too low.	<ul style="list-style-type: none">● Increase oven temperature and decrease the cooking duration.
The glass on the oven door steams up when the oven is hot.	There is a difference between the oven and ambient room temperature.	<ul style="list-style-type: none">● This is normal, and has no effect on your oven's performance.

For Serious Faults:

- Some minor faults can be fixed by referring to the table above, however if an emergency or serious fault occurs, immediately set all controls to their off positions and disconnect the power from the source.
- If a serious fault occurs, DO NOT attempt any repairs yourself, instead wait for a service agent to do so.
- For assistance or to organize an authorised service agent contact our After Sales Support by calling 1300 11 4357, or by emailing support@residentiagroup.com.au
- Please note that if a service agent is asked to attend whilst the product is under warranty and finds that the problem is not the result of an appliance fault, then you may be liable for the cost of the call out charge.
- The appliance must be accessible for the service agent to perform any necessary repair. If your appliance is installed in such a way that a service agent is concerned that damage will be caused to the appliance or your kitchen, then they will not complete a repair.
- Refer to the Warranty Information to learn more.

THIS PAGE IS INTENTIONALLY LEFT BLANK

Technical Specifications

Specifications Chart

Model	IU9EIB
Total Capacity	121L Gross Capacity
Oven Shelf Positions	4 x Shelf Positions
Rated Voltage	220-240V~ / 380-415V~ 3N
Rated Frequency	50-60Hz
Rated Power (Cooktop/Oven)	7.4kW / 2.94kW
Rated Maximum Power	10.34kW
Cooktop Zone A	1800-3000W / 200 x 200mm
Cooktop Zone B	1800-3000W / 200 x 200mm
Cooktop Zone C	3000-4000W / Ø 280mm
Cooktop Zone D	1400-2000W / Ø 140mm
Cooktop Zone A + B (Bridge Zone)	3000-4000W / 200 x 400mm
Weight (Net / Gross)	77.5kg / 79.5kg
Dimensions (W x D x H)	895 x 595 x 858-918 mm

Wiring Diagram

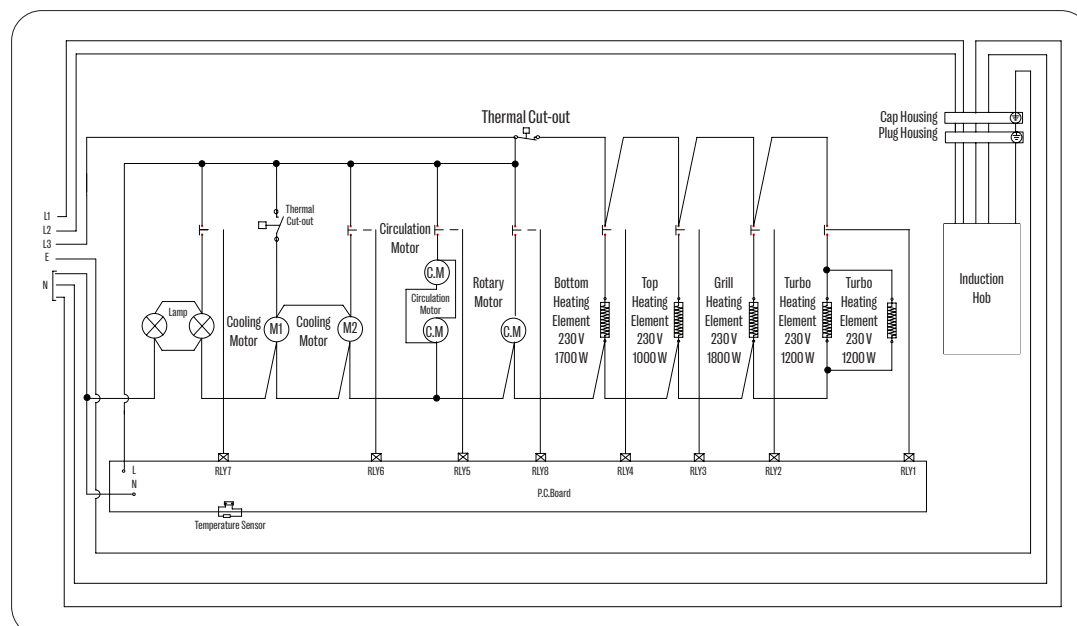

Attach your receipt
to this page



Purchase Details

For future reference, please record the following information which can be found on the rating plate and the date of purchase which can be found on your sales invoice.

STORE DETAILS

STORE NAME | _____

ADDRESS | _____

TELEPHONE | _____ PURCHASE DATE | _____

PRODUCT DETAILS

MODEL NO. | _____

SERIAL NO. | _____

Warranty Information

AUSTRALIAN WARRANTY TERMS & CONDITIONS COOKING APPLIANCES

This document sets out the terms and conditions of the product warranties for Residentia Group Appliances. It is an important document. Please keep it with your proof of purchase documents in a safe place for future reference should you require service for your Appliance.

1. IN THIS WARRANTY

- (a) 'acceptable quality' as referred to in clause 10 of this warranty has the same meaning referred to in the ACL;
 - (b) 'ACL' means Trade Practices Amendment (Australian Consumer Law) Act (No.2) 2010;
 - (c) 'Appliance' means any Residentia Group product purchased by you accompanied by this document;
 - (d) 'ASR' means Residentia Group authorised service representative;
 - (e) 'Residentia Group' means Residentia Group Pty Ltd of 165 Barkly Avenue Burnley VIC, ACN 600 546 656 in respect of Appliances purchased in Australia;
 - (f) 'major failure' as referred to in clause 10 of this warranty has the same meaning referred to in the ACL and includes a situation when an Appliance cannot be repaired or it is uneconomic for Residentia Group, at its discretion, to repair an Appliance during the Warranty Period;
 - (g) 'Warranty Period' means:
 - (i) where the Appliance is used for personal, domestic or household use (i.e. normal single family use) as set out in the instruction manual, the Appliance is warranted against manufacturing defects for 24 months (or 36 months where a valid extended warranty registration has occurred), following the date of original purchase of the Appliance;
 - (h) 'you' means the purchaser of the Appliance not having purchased the Appliance for re-sale, and 'your' has a corresponding meaning.
2. This warranty only applies to Appliances purchased and used in Australia and is in addition to (and does not exclude, restrict, or modify in any way) any non-excludable statutory warranties in Australia.
 3. During the Warranty Period Residentia Group or its ASR will, at no extra charge if your Appliance is readily accessible for service, without special equipment and subject to these terms and conditions, repair or replace any parts which it considers to be defective. Residentia Group or its ASR may use remanufactured parts to repair your Appliance. You agree that any replaced Appliances or parts become the property of Residentia Group. This warranty does not apply to light globes, batteries, filters, seals, or similar perishable parts.
 4. Parts and Appliances not supplied by Residentia Group are not covered by this warranty.
 5. You will bear the cost of transportation, travel and delivery of the Appliance to and from Residentia Group or its ASR. If you reside outside of the service area, you will bear the cost of:
 - (a) travel of an authorised representative;
 - (b) transportation and delivery of the Appliance to and from Residentia Group or its ASR, in all instances, unless the Appliance is transported by Residentia Group or its ASR, the Appliance is transported at the owner's cost and risk while in transit to and from Residentia Group or its ASR.
 6. Proof of purchase is required before you can make a claim under this warranty.
 7. You may not make a claim under this warranty unless the defect claimed is due to faulty or defective parts or workmanship. Residentia Group is not liable in the following situations (which are not exhaustive):

-
- (a) the Appliance is damaged by:
 - (i) accident
 - (ii) misuse or abuse, including failure to properly maintain or service
 - (iii) normal wear and tear
 - (iv) power surges, electrical storm damage or incorrect power supply
 - (v) incomplete or improper installation
 - (vi) incorrect, improper or inappropriate operation
 - (vii) insect or vermin infestation
 - (viii) failure to comply with any additional instructions supplied with the Appliance;
 - (b) the Appliance is modified without authority from Residentia Group in writing;
 - (c) the Appliance's serial number or warranty seal has been removed or defaced;
 - (d) the Appliance was serviced or repaired by anyone other than Residentia Group, an authorised repairer or ASR.
8. This warranty, the contract to which it relates and the relationship between you and Residentia Group are governed by the law applicable where the Appliance was purchased.
 9. To the extent permitted by law, Residentia Group excludes all warranties and liabilities (other than as contained in this document) including liability for any loss or damage whether direct or indirect arising from your purchase, use or non use of the Appliance.
 10. For Appliances and services provided by Residentia Group in Australia, the Appliances come with a guarantee by Residentia Group that cannot be excluded under the Australian Consumer Law. You are entitled to a replacement or refund for a major failure and for compensation for any other reasonably foreseeable loss or damage. You are also entitled to have the Appliance repaired or replaced if the Appliance fails to be of acceptable quality and the failure does not amount to a major failure. The benefits to you given by this warranty are in addition to your other rights and remedies under a law in relation to the Appliances or services to which the warranty relates.
 11. At all times during the Warranty Period, Residentia Group shall, at its discretion, determine whether repair, replacement or refund will apply if an Appliance has a valid warranty claim applicable to it.
 12. Missing parts are not covered by warranty. Residentia Group reserves the right to assess each request for missing parts in a case by case basis. Any parts that are not reported missing in the first week after purchase will not provide free of charge.
 13. To enquire about claiming under this warranty, please follow these steps:
 - (a) carefully check the operating instructions, user manual and the terms of this warranty;
 - (b) have the model and serial number of the Appliance available;
 - (c) have the proof of purchase (e.g. an invoice) available;
 - (d) telephone the numbers shown below.
 14. You accept that if you make a warranty claim, Residentia Group and its ASR may exchange information in relation to you to enable Residentia Group to meet its obligations under this warranty.
- IMPORTANT**
Before calling for service, please ensure that the steps in point 13 have been followed.
- Telephone contact
- ▶ Service: Please call 1300 11 HELP (4357)
-

The Australian Consumer Law requires the inclusion of the following statement with this warranty:

Our goods come with guarantees that cannot be excluded under the Australian Consumer Law. You are entitled to a replacement or refund for a major failure and for compensation for any other reasonably foreseeable loss or damage. You are also entitled to have the goods repaired or replaced if the goods fail to be of acceptable quality and the failure does not amount to a major failure.

THIS PAGE IS INTENTIONALLY LEFT BLANK

Warranty Information (Continued)

NEW ZEALAND WARRANTY TERMS & CONDITIONS COOKING APPLIANCES

To help care for your investment, be sure to register your appliance online. Registration will help you if you need to arrange service in the future, and serves as a record of your purchase – including critical information like model number and serial number – that you can refer to at any time.

Simply visit the below website, or ask your retailer for help: www.inalto.house/nz/registration

WARRANTY:

These products are covered by a warranty for a period of 24 months from the date of purchase, subject to the following conditions*. The warranty covers rectification free of charge of any fault arising from defective materials or components, or faulty workmanship or assembly.

* The conditions above mentioned are:

1. That the purchaser carefully follows all instructions packed with the product;
2. That the purchaser and/or installer carefully follows the installation instructions provided and complies with electrical wiring regulations, gas and/or plumbing codes;
3. That the purchaser carefully follows instructions provided in the owner's handbook relating to the proper use and care of the product and does not use the product for any purpose other than the domestic use for which it has been designed;
4. Commercial use of the product for professional or industrial purposes will void this warranty.;
5. That the product was purchased and installed in New Zealand;
6. That this warranty does not extend to:
 - a) optional glass lids for hobs apart from claims which relate to mechanical or physical damage thereof at the date of purchase;
 - b) 'consumable' parts such as light bulbs or filters;
 - c) damage to ceramic glass caused by liquid or solid spill-overs, lack of maintenance, or impact;
 - d) damage to surface coatings caused by cleaning or maintenance using products not recommended by the owner's handbook;
 - e) defects caused by normal wear and tear, accident, negligence, alteration, misuse or incorrect installations;
 - f) a product dismantled, repaired or serviced by any serviceman other than an authorised service agent;

- g) a product not in possession of the original purchaser;
 - h) damage caused by power outages or surges
 - i) damage caused by pests (eg. rats, cockroaches etc.)
7. That if the product is a freestanding microwave oven or small appliance it must be returned to the dealer/retailer for servicing. These products, unless stated otherwise, have a 12 month warranty from original date of purchase with 24 months on the microwave magnetron; Waste disposers have a 12 month warranty.
8. The provision of service under this warranty is limited by a 25km boundary from the retailer where the product was purchased except for microwaves. Such travelling outside of these limits will incur commercial cost to be paid by you, regulated by the number of kilometres travelled beyond the 25km limit (50km return trip). Microwaves are to be delivered to the nearest authorised service agent by the customer.

Please refer to your user manual for any further conditions that may apply to your specific model.

Nothing herein contained shall be construed in any way as excluding or limiting your rights under the Consumer Guarantees Acts 1993.

For Service please visit www.applico.co.nz/service or contact the dealer/retailer from whom you purchased the product from or call the 0800 number listed below. If you are unable to establish the date of purchase, or the fault is not covered by this warranty, or if the product is found to be in working order, you will be required to bear all service call charges.

Registration of this warranty constitutes acceptance of the terms and conditions of this warranty.

Should you require any assistance, please call Customer Services on 0800 763 448.

Distributed by Applico Ltd.
www.applico.co.nz
July 2019

After registering your appliance online, we recommend you fill out the below information for your reference and keep this warranty card in a safe place.

THIS WARRANTY IS VALID IN NEW ZEALAND ONLY.

DESIGNED IN MELBOURNE

INALTO

FOR ALL AUSTRALIAN HOMES

—
WWW.INALTO.HOUSE



E2447