

MODEL  
IVDE45W

VENTED CLOTHES DRYER  
4.5KG CAPACITY

INALT<sup>®</sup>

CLASSIQUE

V 1.1

**USER MANUAL**

# PURCHASE DETAILS



For future reference, please record the following information which can be found on the rating plate and the date of purchase which can be found on your sales invoice.

The rating plate of your dryer is located on the rear of the appliance. Therefore please fit the duplicate data plates or label on the outside of the cupboard to sure that the label can be easily seen during operation.

---

## STORE DETAILS

---

STORE NAME |

ADDRESS |

TELEPHONE |

PURCHASE DATE |

---

## PRODUCT DETAILS

---

MODEL NO. |

SERIAL NO.\* |

# CONTENTS

- 2** Purchase Details
- 5** Welcome
- 6** General Safety Instructions
- 10** Product Overview
- 12** Getting Started: Installation
- 17** Instructions
- 20** FAQs
- 21** Other Useful Information
- 26** Warranty

THIS PAGE  
IS INTENTIONALLY  
LEFT BLANK



# WELCOME



## Residentia Group

–  
Head Office.  
165 Barkly Ave  
Burnley  
Victoria 3121  
Australia

–  
ACN.  
600 546 656

–  
Online.  
residentia.group

## InAlto

www.inalto.house  
 / inalto.house  
 / inalto.house

---

Congratulations on purchasing your new Clothes Dryer. The InAlto brand is proudly distributed within Australia by Residentia Group Pty Ltd.

Please refer to the warranty card at the rear of this manual for information regarding your product's parts and labour warranty, or visit us online at:

→ [www.residentia.group](http://www.residentia.group)  
→ [www.inalto.house](http://www.inalto.house)

At Residentia Group, we are customer obsessed and our Support Team are there to ensure you get the most out of your appliance. Should you want to learn more about recommended drying temperatures, the various features of your Dryer, and importantly taking care of your appliance when cleaning, our Support Team are here to help.

You can use our online Support Centre at anytime by visiting <http://support.residentiaigroup.com.au>, or you can contact us via calling us on 1300 11 HELP (4357).

It is important that you read through the following use and care manual thoroughly to familiarise yourself with the installation and operation requirements of your appliance to ensure optimum performance.

Again, thank you for choosing an InAlto appliance and we look forward to being of service to you.

Kind Regards,  
The Residentia Team

# General Safety Instructions

## IMPORTANT SAFETY INSTRUCTIONS READ CAREFULLY AND KEEP FOR FUTURE REFERENCE

Read this manual thoroughly before first use, the safety precautions enclosed herein reduce the risk of fire, electric shock and injury when correctly adhered to. Keep the manual in a safe place for future reference, along with the completed warranty card and purchase receipt. If applicable, pass these instructions on to the next owner.

**Always follow basic safety precautions and accident prevention measures when using an electrical appliance, including the following:**

### Electrical safety and cord handling

- **Voltage:** Make sure your outlet voltage and circuit frequency correspond to the voltage indicated on the appliance rating label and your outlet socket is properly earthed. If this is not the case, do not use the dryer.
- **Separate circuit:** We strongly recommend you connect the appliance to a separate circuit serving only this appliance. This provides the best performance and prevents overloading the house wiring circuits that could cause a fire hazard from overheating.
- **Electrical hazard:** Do not insert any objects into the appliance.
- **No extension cord:** Do not use this appliance with a power adaptor or extension cord. **CAUTION:** If such a device must be used, the cord or outlet device must be positioned so that it is not subject to splashing or ingress of moisture.
- **Protect the power cord.** Do not kink or damage the power cord. Position the cord out of the way so no one steps on or places anything on the cord or against it. Do not run the cord under floor coverings. Arrange the cord away from traffic areas where it will not become a trip hazard.
- **Damage:** Do not operate the appliance after it malfunctions or has been dropped or damaged. In case of damage, contact the after sales support line for advice.
- **Damaged cord:** If the power supply cord is damaged, do not attempt to change it yourself. A damaged cord or plug must be replaced by the manufacturer or a qualified person in order to avoid a hazard.
- **Disconnect:** Unplug the clothes dryer from the power supply after use, before cleaning, servicing or moving the appliance. To disconnect, turn the appliance off, switch off the power outlet and remove the plug from the power outlet. Grip the plug when disconnecting; do not pull on the cord. After disconnection, wait at least two minutes before turning the appliance back on again.
- **RCD:** Unless your home is already fitted with a residual current device (safety switch), we recommend installing an RCD with a rated residual operating current not exceeding 30mA to provide additional safety protection when using electrical appliances. See your electrician for professional advice.

### Usage conditions and restrictions

- **Domestic use only:** This appliance is intended for indoor household use only. It is not intended for industrial, commercial or trade use. Do not use it outdoors. Do not use it for anything other than its intended purpose (drying domestic quantities of washing), and only use it as described in this manual.

# General Safety Instructions (Cont.)

- **Usage restriction:** The appliance is not intended for use by persons (including children) with reduced physical, sensory or mental capabilities, or lack of experience and knowledge, unless they have been given supervision or instruction concerning use of the appliance by a person responsible for their safety.
- **Children:** Supervise children to ensure they do not play with the appliance. Close supervision is necessary when any appliance is used by or near children.
- **Installation requirements:** Do not install the appliance in a tight fitting cabinet. Do not install it near heat sources such as radiators, heaters, air ducts or direct sunlight. If the clothes dryer is not wall-mounted, place it on a flat, firm, dry and stable floor in a well ventilated area. Use the adjustable legs to assist in levelling the dryer if required. Do not place it on any soft material such as foam or plastic.
- **Ventilation:** Do not block any ventilation openings. Ensure that vents are not covered by newspapers, tablecloths, curtains, etc.
- **Before use:** Make sure to remove transport packaging at the rear of the dryer.  
**WARNING:** Before loading the dryer, always ensure no pet or young child has climbed into it. Do not overload the clothes dryer.
- **Suitability for tumble drying:** Only load suitable items into the clothes dryer. See the box on the opposite page for which items and materials are unsuitable for the clothes dryer and may present a fire risk.
- **Preparation:** Make sure all pockets of clothing to be dried are empty. Hard, sharp objects such as coins, safety pins, bra wires, nails, screws, lighters or matches must be removed as they can cause extensive damage to the dryer.  
**WARNING:** Any damage or malfunction resulting from foreign objects is not covered by your warranty and may lead to expensive repairs.
- **No dripping water:** All clothes must be thoroughly spin-dried before placing them in the dryer. Dripping water may cause an electrical hazard.
- **No open flames:** Do not place open flame sources such as candles on the dryer.
- **Hot surface:** The door window may be hot after a long drying cycle. Always ensure children are kept away from the machine.
- **Cool down:** The final part of a clothes dryer cycle occurs without heat (cool down cycle) to ensure that the items are left at a temperature that will not damage them.  
**WARNING:** Never stop the clothes dryer before the end of the drying cycle unless all items are removed quickly and spread out so that the heat is dissipated.
- **Subsequent cycles:** After turning off the power supply to the clothes dryer, wait at least two minutes before turning it back on again.
- **Repair:** Except for the filters that require cleaning, this appliance contains no user-serviceable parts inside. Do not attempt to open, disassemble or repair it yourself; only have it serviced by qualified personnel, call the after sales support line.
- **Liability:** Improper use or installation may result in the risk of fire, electric shock and/or injury. We assume no liability for any eventual damages caused by improper use or handling, or by any other noncompliance with the instructions in this manual.

# General Safety Instructions (Cont.)

## CAUTION!

The items listed below are **UNSUITABLE** for clothes drying. They can cause fire in the clothes dryer or extensive damage. **DO NOT** place the following items into the clothes dryer.

- Items containing foam rubber (also known as latex foam) or similarly textured rubber-like materials — when heated, these materials can spontaneously combust and cause a fire.
- Items that have been spotted or soaked with cooking oil, or with highly flammable substances — these substances constitute a fire hazard. Highly flammable substances used in domestic environments include acetone, alcohol, petrol, kerosene, some stain removers, dry-cleaning solvents, turpentine, waxes, wax removers and some hair care products. (This also includes items that have previously been cleaned or spotted with dry-cleaning solvents or other flammable or explosive substances.)
- Washing these items thoroughly beforehand in hot water with an extra amount of detergent will reduce, but not necessarily eliminate the hazard. The 'cool down' cycle of a clothes dryer should be used to reduce the temperature of the items. They should not be removed from the clothes dryer or piled or stacked while hot.
- Undergarments that contain metal reinforcements (such as underwire bras), which can come loose during drying and damage the clothes dryer.
- Plastic articles such as shower caps or waterproof baby bibs.
- Rubber-backed articles, clothes fitted with foam rubber pads, pillows, galoshes and rubber coated tennis shoes.
- Fabric softeners or similar products, unless they are specifically recommended by the product manufacturer for use in a clothes dryer to eliminate the effects of static electricity.

## CAUTION!

- Do not use the tumble dryer if industrial chemicals have been used for cleaning.
- Do not dry unwashed items in the tumble dryer.
- Do not allow lint to accumulate around the tumble dryer. Clean the filter after every use.
- Adequate ventilation has to be provided to avoid the back-flow of gases into the room from appliances burning other fuels, including open fires.



**WARNING: Risk of fire**

This symbol alerts you to take care as oil-affected items can ignite spontaneously, especially when exposed to heat, such as in a clothes dryer. The items become warm, causing an oxidation reaction in the oil. Oxidation creates heat. If the heat cannot escape, the items can become hot enough to catch fire. Piling, stacking or storing oil-affected items can prevent heat from escaping and so create a fire hazard.



This symbol alerts you to take care of a potential hot surface. As some surfaces with this item become hot, please do not touch them while during a cycle.

# General Safety Instructions (Cont.)

## Warning and Caution

- Oil affected items can ignite spontaneously, especially when exposed to heat sources such as in a tumble dryer. The items become warm, causing an oxidation reaction in the oil. Oxidation creates heat. If the heat cannot escape, the items can become hot enough to catch fire. Piling, stacking or storing oil-affected items can prevent heat from escaping and so create a fire hazard.
- If it is unavoidable that fabrics that contain vegetable or cooking oil or have been contaminated by hair care products be placed in a tumble dryer they should first be washed in hot water with extra detergent - this will reduce, but not eliminate, the hazard.
- Remove all objects from pockets such as lighters and matches.
- **WARNING:** Never stop a tumble dryer before the end of the drying cycle unless all items are quickly removed and spread out so that the heat is dissipated.
- **WARNING:** The appliance must not be supplied through an external switching device, such as a timer, or connected to a circuit that is regularly switched on and off by a utility.
- That the appliance must not be installed behind a lockable door, a sliding door or a door with a hinge on the opposite side to that of the tumble dryer, in such a way that a full opening of the tumble dryer door is restricted.

# Product Overview

## Front View

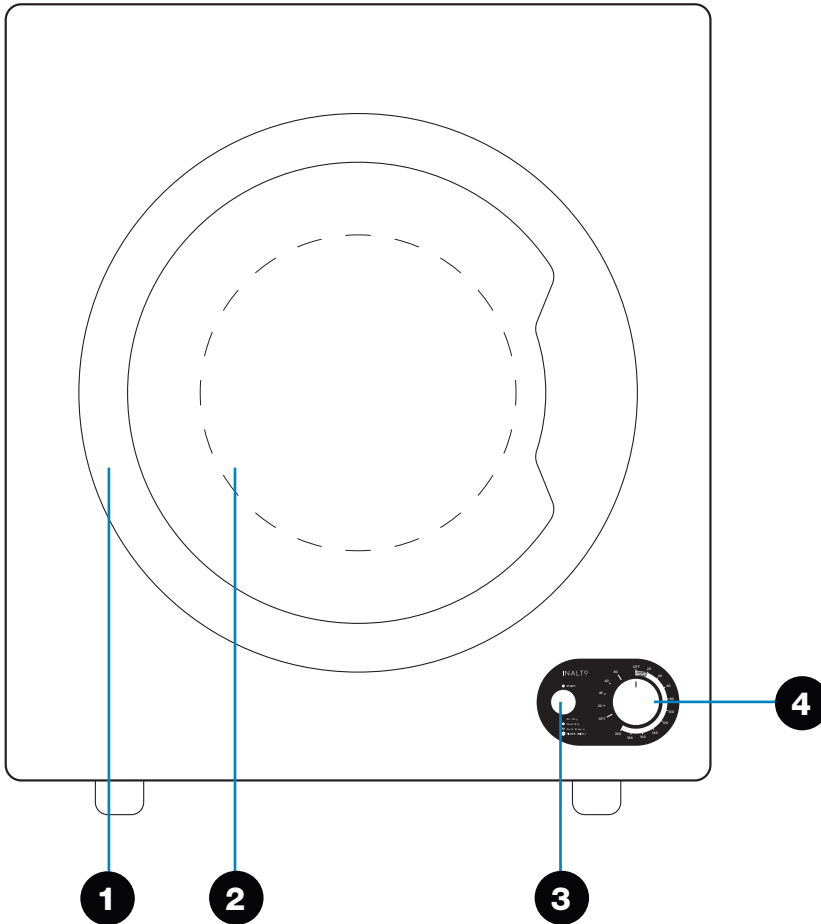

### KEY

- 1 Door
- 2 Window
- 3 Start Button
- 4 Program Selector / Timer

# Product Overview (Cont.)

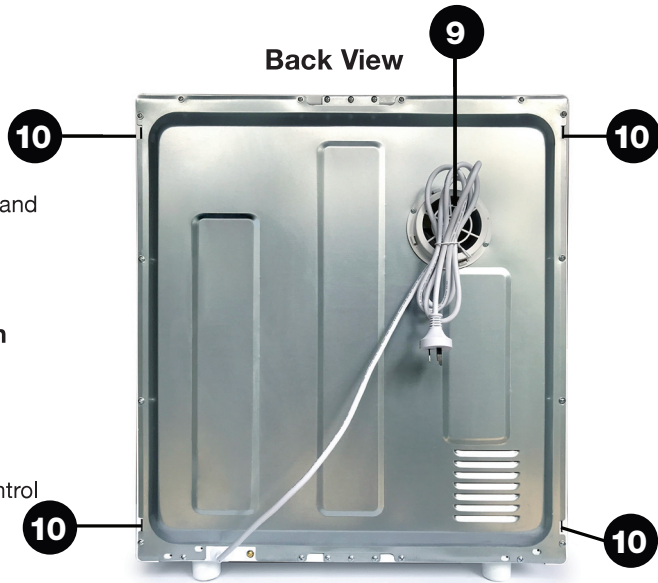
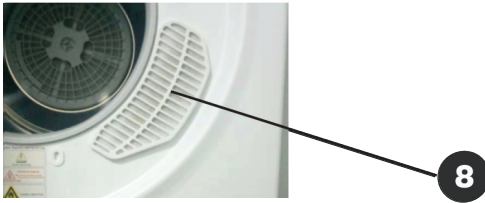

8 Air intake shroud and filter

9 Exhaust vent

10 Mounting holes

**B Documentation**  
(not shown)





Instruction manual

Quick start guide

Warranty certificate

Alternative printed control panel

**C Wall-Mounting Kit**

Parts of the Wall-Mounting Kit		
Part	Illustration	Quantity
Hanging brackets		2
Spacers		2
Exhaust Connector		1
12mm Screws		4
25mm Screws		4

# Getting Started: Installation

## Unpacking

- This product has been packaged to protect it against transportation damage. Unpack it and keep the original packaging carton and materials in a safe place. It will help prevent any damage if the product needs to be transported in the future, and you can use it to store the appliance when it is not in use. In the event that it is to be disposed of, please recycle all packaging materials where possible.
- Plastic wrapping can be a suffocation hazard for babies and young children, so ensure all packaging materials are out of their reach. Dispose of packaging safely.
- Make sure to remove the transport packaging at the rear of the clothes dryer.
- Inspect the cord and plug for damage or wear before each use. Do not use the appliance if the appliance or its cord have been damaged or are not working properly. **In case of damage, contact our after sales support centre.**
- Read all instructions in this manual and make sure you understand all warnings.
- Wipe the inside of the drum with a damp cloth to remove any dust from transport.

## Installation

**CAUTION:** This appliance is heavy. Use two or more people to move and install it.

- This clothes dryer can be installed on the floor level (as supplied, or upside down with the control panel at the top), or wall-mounted (as supplied). Detailed instructions for each option are provided on the following pages.
- The appliance must not be installed behind a lockable door, sliding door or a door with a hinge on the opposite side of the clothes dryer, in such a way that a full opening of the tumble dryer door is restricted.
- All electrical connections must be made by qualified personnel.
- Install the dryer in a dry, well ventilated area, away from heat and direct sunlight. Do not install it in a tight fitting cabinet
- Exhaust air must not be discharged into a flue which is used for exhausting fumes from appliances burning gas or other fuels.

### Floor level installation

- If the dryer is installed on the floor, make sure to place it on a firm, flat, dry and stable floor, close to a wall outlet. Do not place it on soft material such as foam, plastic or carpet, as this will block the air intake.
- The dryer comes with legs to ensure stability. If you are installing it with the control panel at the top, you will need to reassemble the legs on the bottom panel. To avoid damaging the floor, lay the dryer on a large piece of cardboard (from the carton) and attach the legs as illustrated (Fig. 1).
- See points 3 and 4 on page 13 for installation of the exhaust connector.
- Stand the dryer on its feet and slide it into position, leaving a space of at least 10cm between the dryer and any wall. All four legs are adjustable; just turn them to assist in levelling the dryer, if necessary. When the dryer is level, tighten the legs.

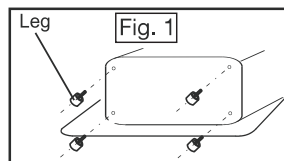



# Getting Started: Installation (Cont.)

## Upside down installation

The dryer can be installed upside down, if this suits your setup better. To prepare the unit for upside down installation, proceed as follows:



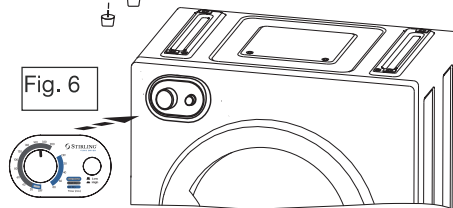
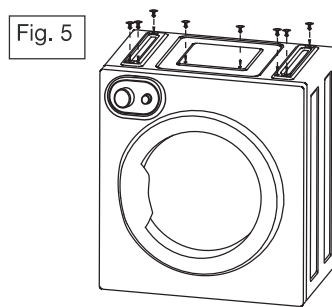
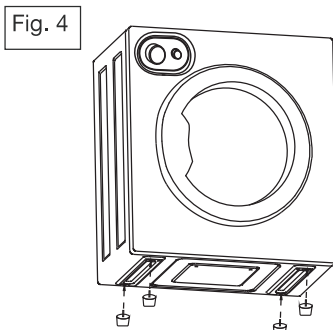
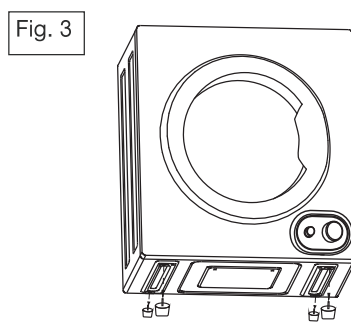
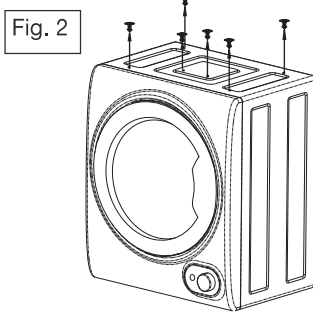

1. Remove the rubber plugs on the top of the unit (Fig. 2). Then remove the four legs from the bottom (Fig. 3).
2. For installation on the floor, place the dryer upside down and install the four legs at the bottom (top side of the original dryer, Fig. 4). (This step is not necessary if wall-mounting the dryer or installing it on a rack above a washer. Do not put the dryer on a washing machine or other appliance.) Push the rubber plugs into the holes on the top of the dryer (bottom of the original dryer, see Fig. 5).
3. There is an additional printed control panel in the accessories bag, place this over the existing panel (Fig. 6).



# Getting Started: Installation (Cont.)

## Wall-mounted installation

- If wall-mounting the dryer above a washer, allow sufficient room to open the lid of a top load washer.
- You will need at least 5cm space between the top of the dryer and the ceiling for ease of installation.
- If you want to mount this dryer directly to your laundry wall, use the supplied wall-mounting kit which contains the following parts:

Parts of the Wall-Mounting Kit		
Part	Illustration	Quantity
Hanging brackets		2
Spacers		2
Exhaust Connector		1
12mm Screws		4
25mm Screws		4

- Additional tools required (for mounting onto a plasterboard/wood stud wall):
  - \* Drill (with a 3mm drill bit)
  - \* Phillips head screwdriver
  - \* 4 Timber screws (ø12x50mm)
  - \* Helper to help lift the dryer onto the wall.
- Wall-mounting instructions follow on the next pages.

## Rack-mounted installation

- If the clothes dryer is to be **rack-mounted**, you will need a secure stand (Fig. 7) to ensure stability and prevent vibration. (The stand is not included.)
- Make sure to leave at least 15cm space between the dryer and the wall (Fig. 8).

Fig. 7

Stand

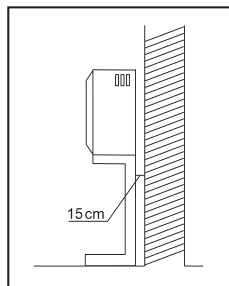
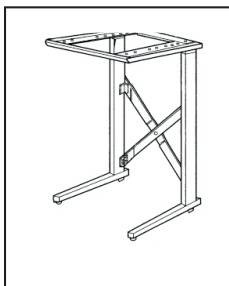

Fig. 8

Clearance

# Getting Started: Installation (Cont.)

## Step-by-step wall-mounting instructions

When mounting the clothes dryer to a plasterboard wall, make sure to attach the wall-mounting bracket securely to a timber stud. If the space between two studs is too wide, fit a timber slat between the studs to mount the brackets securely onto the studs (Fig. 9).

Fig. 9

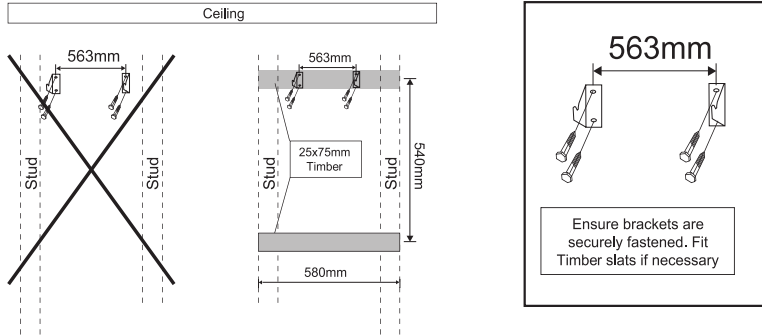

1. Determine the dryer position on the wall and mark the required bracket position.
2. Fix the two wall-hanging brackets securely to the timber stud (Fig. 10). Align the hanging hooks and fasten the screws tightly.

Fig. 10

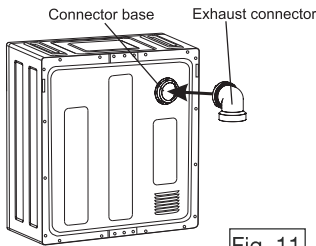
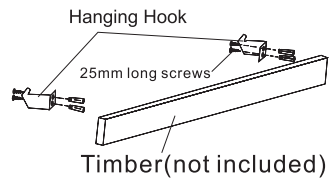
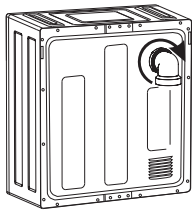

Fig. 11



3. To install the exhaust connector, push the connector over the exhaust vent at the back of the dryer with the exhaust outlet in the direction required (Fig. 11).
4. Please adjust the exhaust connector direction, then, match the exhaust connector onto the connector.

# Getting Started: Installation (Cont.)

5. Use the four 12mm screws to attach the two spacers (Fig. 12).

Fig. 12

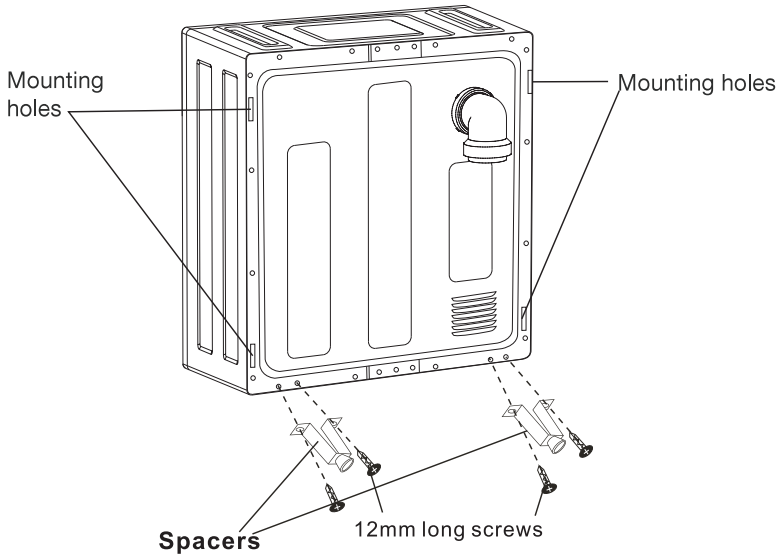

6. With assistance, mount the clothes dryer onto the wall bracket (Fig. 13).
7. Once the clothes dryer is properly installed, plug the electrical cord into an appropriately earthed three pin 240V wall socket.

Fig. 13

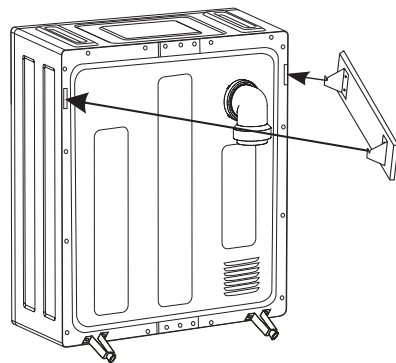

## NOTE

If you are attaching a flexible duct (not supplied) to the exhaust outlet, make sure to keep it as short as possible, as long exhaust ducts reduce the efficiency of the machine, and may hinder its operation.

# Instructions

## CAUTION!

Make sure you read all safety precautions in this manual and are aware of the items (listed on page 7) that cause a hazard if placed in the clothes dryer.

## Loading the Dryer

- Prior to loading the dryer, check that none of the items have the following symbols anywhere on them, which indicate that items are UNSUITABLE for clothes drying.

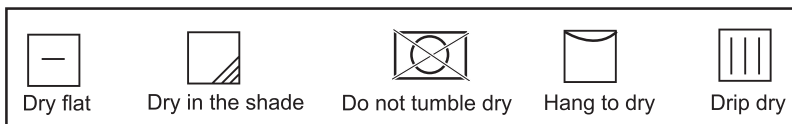

- The clothes dryer is intended only for drying textile material that has been washed in water **and well spin-dried**. Dripping water may cause an electrical hazard.
- Ensure that the items to be dried do not have combustible materials or foreign objects (such as lighters, hair pins, coins) inside pockets.
- Clean the lint filter before each use (see page 21) and make sure it is properly in place.
- To avoid items getting tangled up in the dryer, which results in uneven drying, we recommend placing items into the dryer one at a time.
- Turn items with zippers inside out and fasten buckles. This will also help reduce impact noise when the items hit against the turning drum.
- As the dryer heat may permanently set stains, ensure you check prior to drying.
- Separate dark and light coloured items as you would do when washing.
- For best results, load the dryer with similar fabrics that take a similar period of time for drying (see page 19 for suggested drying times).
- Place small, delicate items in a mesh bag; do not put too many items into one bag. (It is not recommended to dry underwire bras in a clothes dryer.)
- When drying large items such as a blanket or sheets, open the dryer door and shake out the item from time to time, then place the item back in the dryer, close the door and press Start. This will ensure even drying.
- **CAUTION: Do not overload the dryer: the maximum amount of dry textile material that can be dried in one load is 4.5kg.**
- When closing the dryer door prior to starting the unit, ensure that items are not jammed in the door.
- Do not add items into the dryer while it is operating. However, if you do open the door during operation, the safety switch will stop the dryer.

# Instructions (Cont.)

## Using the Dryer

The control panel at the front of the clothes dryer consists of a Drying Program Selector/Timer Dial (1) and the Start Button (2)

### Start button

After having set up the Heat Selector and Timer Dial, press the Start Button. The dryer will start and work until the program is finished.

**NOTE:** If during the drying process the door is opened (or power is switched off), the dryer will stop working. In order to restart it, you will need to close the door (or switch the power back on) and then press the Start Button. The dryer will resume operation.

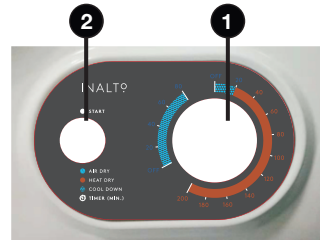

### Drying Program Selector

There are four drying combinations available: Cool, Warm, Hot and Air dry.

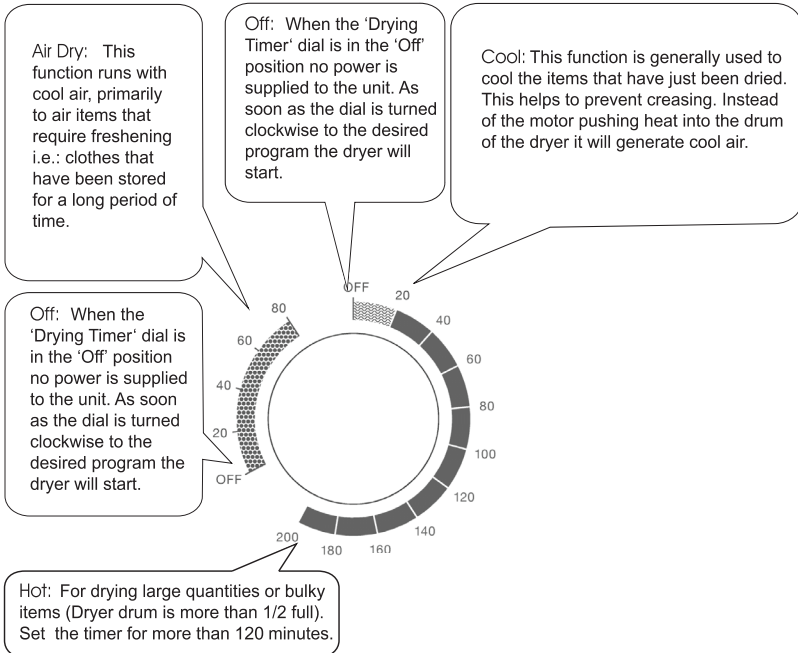

# Instructions (Cont.)

## 3 Start button

- After having set up the Heat Selector and Timer Dial, press the Start button. The dryer will start and work until the program is finished.
- If during the drying process the door is opened (or power is switched off), the dryer will stop working. In order to restart it, you will need to close the door (or switch the power back on) and then press the Start button. The dryer will then resume operation.

**NOTE:** This Start button is only designed to start operation of the dryer. If you press this button during the drying process, the dryer will not pause. In order to stop the dryer, you must turn the timer dial to the Off position.

## Suggested Drying Times

Drying Capacity	Drying Time	
	High	Low
Approximately 1kg	Approximately 30min.	Approximately 55min.
Approximately 2kg	Approximately 60min.	Approximately 110min.
Approximately 3kg	Approximately 120min.	
Approximately 4.5kg	Approximately 200min.	

Drying times can be affected by many factors, such as type of material, bulkiness of the items, how full the dryer is, etc. The above list is only a guide.



# FAQs

## Troubleshooting Guide

If your clothes dryer has a fault, is not working properly, or you think it should work better, use the list below to identify and solve any problems. If you cannot solve the problem, contact our after sales support centre. Do not attempt to dismantle or repair the dryer yourself.

Problem	Possible cause	Solution
The timer dial does not turn.	Is the power plug inserted firmly into the wall socket?	Insert the power plug firmly.
The drum does not turn.	Is the door closed? Did you press the Start button?  Is the power plug firmly inserted? Does the wall socket have power?	Close the door. After setting up the Heat Selector and Timer Dial, you must press the Start button. Insert the power plug firmly. If power is switched on at the wall socket, check the socket with another appliance.
Hot air is not blowing out.	Is the timer incorrectly set to cold air?	Set the timer to hot air.
The washing is not thoroughly dried.	Are the front and back filters clogged? Is there too much washing in the dryer? Have items been added while the dryer is in operation? Has the washing been twisted while drying? Is the dryer operating in a small and poorly ventilated area? Have you set the dryer to less than 60 minutes on the Mild Dry program (low heat)?	Check and clean the filters. Reduce the amount of washing in the dryer. Dry damp items again for a little longer. Untwist the items and dry them for a little longer. Place the dryer in a well-ventilated area. Try using a longer drying time, or select high heat, if your items allow.
The dryer does not start.	Is there a power failure?  Is the power plug inserted firmly? Is the door closed? Is the timer in the OFF position? Is the power switched on at the wall socket?	Check and try again when the power is back. Insert the power plug firmly. Close the door securely. Set the drying time and press the Start button. Switch on power at the wall socket.



# Other Useful Information

## Maintenance

To prolong the service life of your clothes dryer, keep it in good condition and clean the filters regularly.

**CAUTION:** Before cleaning or maintenance, unplug the dryer from the wall socket.

### Cleaning the lint filter

**The lint filter must be in place whenever drying. It must be cleaned before each use.**

1. To remove the filter, insert your fingers into the four holes around the exhaust vent shroud and pull out the filter assembly. It consists of three parts: the exhaust vent shroud, the lint filter and the exhaust filter (Fig. 14).

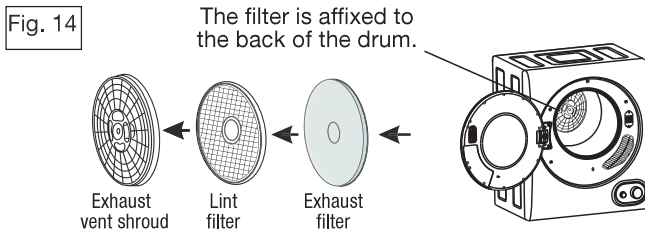

2. Separate the three parts (exhaust vent shroud, lint filter and exhaust filter) and, using a soft brush, cloth or vacuum cleaner, clean any lint off the lint filter and exhaust filter (Fig. 15). Take care not to damage the filters.

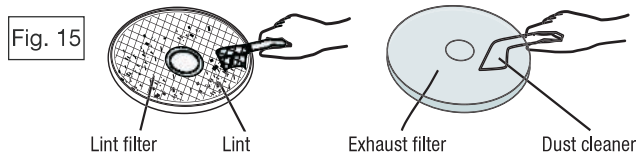

3. After cleaning, assemble the parts in the sequence of exhaust filter - lint filter - exhaust vent shroud (Fig. 16), aligning the recesses in the centre with the projection in the centre of the drum. Make sure that the filter assembly is firmly inserted.

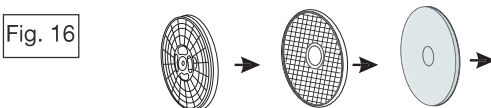

**NOTE:** The metal grid fixed on the rear of the drum should also be cleaned with a soft cloth or brush.

# Other Useful Information (Cont.)

## Cleaning the air intake filter

- The air intake filter at the front of the unit should be cleaned about once a month.
- To remove the filter, hold the upper and lower ends of the air intake shroud and pull it outwards (Fig. 17).
- Remove the filter inside the shroud and clean it with a soft brush.
- Reassemble and push the filter back until it clicks into place.

Fig. 17

Slightly push the shroud upwards with your thumb until the latch hook disconnects, then remove.

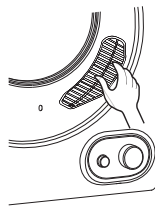

## Cleaning the interior and exterior of the dryer

- To clean the exterior surfaces of the clothes dryer, only use a dry cloth, or a cloth dampened with water and a little mild detergent.
- Do not wash exterior or interior surfaces directly with water.
- Do not use solvents, thinner, alcohol based or harsh or abrasive cleaners on any of the dryer surfaces.
- Do not use any type of spray cleaner when cleaning the interior. If the dryer drum becomes stained, clean the drum with a damp cloth.
- If cleaning the drum has left any residues on the drum, make sure to remove it before drying the next load.

## Storage

If you are not going to use the appliance for an extended period of time, unplug it and store it upright in the original carton to protect it from dust. Store the unit in a dry place, out of children's reach.

# Other Useful Information (Cont.)

## **Service, Repair and Spare Parts**

If the appliance is damaged, **do not attempt to repair it yourself.** Contact our after sales support centre to arrange for examination or repair of the product.

The following spare parts for the IVDE45W 4.5kg Clothes Dryer are available for purchase from our after sales support centre. To purchase a spare part, call the centre on 1300 114 357 or email us at [support@residentiagroup.com.au](mailto:support@residentiagroup.com.au)

- Bearings for drum
- Capacitor
- Door handle assembly
- Door hinge
- Door lock
- Door lock base
- Door seal
- Drum belt
- Drum motor
- Exhaust filter
- Exhaust vent shroud
- Fan
- Fan assembly
- Fan belt
- Fan motor
- Heating element
- Levelling feet
- Lint filter
- Pulley
- Thermostat
- Timer
- Wall mount with screws

## Other Useful Information (Cont.)

### Technical Specifications

Product	4.5kg Clothes Dryer
Model Number	IVDE45W
Capacity	4.5kg
Voltage & Frequency	220-240V AC - 50-60Hz
Rated Input Power	1400W
Dimensions	600 (W) x 435 (D) x 700 (H) mm
Net Weight	21kg
Ingress Protection	IPX4

### Compliance

This appliance has been fully tested and meets all requirements as set out by standards AS/NZS 60335.1 and AS/NZS 60335.2.11.

### Responsible Disposal

At the end of its working life, do not throw this appliance out with your household rubbish. Electrical and electronic products contain substances that can have a detrimental effect on the environment and human health if disposed of inappropriately. Observe any local regulations regarding the disposal of electrical consumer goods and dispose of it appropriately for recycling. Contact your local authorities for advice on recycling facilities in your area.

**NOTE:** Due to continued product improvement, images and illustrations in this manual may vary slightly from the product purchased. All images in this manual are for reference only.

This page  
is intentionally  
left blank

# WARRANTY INFORMATION

---

## WARRANTY TERMS AND CONDITIONS CLOTHES DRYER

This document sets out the terms and conditions of the product warranties for Residentia Group Appliances. It is an important document. Please keep it with your proof of purchase documents in a safe place for future reference should you require service for your Appliance.

### 1. IN THIS WARRANTY

- (a) 'acceptable quality' as referred to in clause 10 of this warranty has the same meaning referred to in the ACL;
  - (b) 'ACL' means Trade Practices Amendment (Australian Consumer Law) Act (No.2) 2010;
  - (c) 'Appliance' means any Residentia Group product purchased by you accompanied by this document;
  - (d) 'ASR' means Residentia Group authorised service representative;
  - (e) 'Residentia Group' means Residentia Group Pty Ltd of 165 Barkly Ave, Burnley VIC 3121, ACN 600 546 656 in respect of Appliances purchased in Australia;
  - (f) 'major failure' as referred to in clause 10 of this warranty has the same meaning referred to in the ACL and includes a situation when an Appliance cannot be repaired or it is uneconomic for Residentia Group, at its discretion, to repair an Appliance during the Warranty Period;
  - (g) 'Warranty Period' means:
    - (i) where the Appliance is used for personal, domestic or household use (i.e. normal single family use) as set out in the instruction manual, the Appliance is warranted against manufacturing defects for 24 months, following the date of original purchase of the Appliance;
  - (h) 'you' means the purchaser of the Appliance not having purchased the Appliance for re-sale, and 'your' has a corresponding meaning.
2. This warranty only applies to Appliances purchased and used in Australia and is in addition to (and does not exclude, restrict, or modify in any way) any non-excludable statutory warranties in Australia.
  3. During the Warranty Period Residentia Group or its ASR will, at no extra charge if your Appliance is readily accessible for service, without special equipment and subject to these terms and conditions, repair or replace any parts which it considers to be defective. Residentia Group or its ASR may use remanufactured parts to repair your Appliance. You agree that any replaced Appliances or parts become the property of Residentia Group. This warranty does not apply to light globes, batteries, filters or similar perishable parts.
  4. Parts and Appliances not supplied by Residentia Group are not covered by this warranty.

- 
5. You will bear the cost of transportation, travel and delivery of the Appliance to and from Residentia Group or its ASR. If you reside outside of the service area, you will bear the cost of:
- travel of an authorised representative;
  - transportation and delivery of the Appliance to and from Residentia Group or its ASR, in all instances, unless the Appliance is transported by Residentia Group or its ASR, the Appliance is transported at the owner's cost and risk while in transit to and from Residentia Group or its ASR.
6. Proof of purchase is required before you can make a claim under this warranty.
7. You may not make a claim under this warranty unless the defect claimed is due to faulty or defective parts or workmanship. Residentia Group is not liable in the following situations (which are not exhaustive):
- the Appliance is damaged by:
    - accident
    - misuse or abuse, including failure to properly maintain or service
    - normal wear and tear
    - power surges, electrical storm damage or incorrect power supply
    - incomplete or improper installation
    - incorrect, improper or inappropriate operation
    - insect or vermin infestation
    - failure to comply with any additional instructions supplied with the Appliance;
  - the Appliance is modified without authority from Residentia Group in writing;
  - the Appliance's serial number or warranty seal has been removed or defaced;
  - the Appliance was serviced or repaired by anyone other than Residentia Group, an authorised repairer or ASR.
8. This warranty, the contract to which it relates and the relationship between you and Residentia Group are governed by the law applicable where the Appliance was purchased.
9. To the extent permitted by law, Residentia Group excludes all warranties and liabilities (other than as contained in this document) including liability for any loss or damage whether direct or indirect arising from your purchase, use or non use of the Appliance.
10. For Appliances and services provided by Residentia Group in Australia, the Appliances come with a guarantee by Residentia Group that cannot be excluded under the Australian Consumer Law. You are entitled to a replacement or refund for a major failure and for compensation for any other reasonably foreseeable loss or damage. You are also entitled to have the Appliance repaired or replaced if the Appliance fails to be of acceptable quality and the failure does not amount to a major failure. The benefits to you given by this warranty are in addition to your other rights and remedies under a law in relation to the Appliances or services to which the warranty relates.
11. At all times during the Warranty Period, Residentia Group shall, at its discretion, determine whether repair, replacement or refund will apply if an Appliance has a valid warranty claim applicable to it.
12. Missing parts are not covered by warranty. Residentia Group reserves the right to assess each request for missing parts in a case by case basis. Any parts that are not reported missing in the first week after purchase will not provide free of charge.
13. To enquire about claiming under this warranty, please follow these steps:
- carefully check the operating instructions, user manual and the terms of this warranty;
  - have the model and serial number of the Appliance available;
  - have the proof of purchase (e.g. an invoice) available;
  - telephone the numbers shown below.
14. You accept that if you make a warranty claim, Residentia Group and its ASR may exchange information in relation to you to enable Residentia Group to meet its obligations under this warranty.
- IMPORTANT**  
Before calling for service, please ensure that the steps in point 13 have been followed.
- CONTACT SERVICE**  
→ Please call 1300 11 HELP (4357)
- 

The Australian Consumer Law requires the inclusion of the following statement with this warranty:

Our goods come with guarantees that cannot be excluded under the Australian Consumer Law. You are entitled to a replacement or refund for a major failure and for compensation for any other reasonably foreseeable loss or damage. You are also entitled to have the goods repaired or replaced if the goods fail to be of acceptable quality and the failure does not amount to a major failure.

AN INITIATIVE BY  
RESIDENTIA GROUP

# INALT<sup>o</sup> CLASSIQUE



E2447

TEL. 1300 11 4357  
SUPPORT@RESIDENTIAGROUP.COM.AU  
WWW.RESIDENTIA.GROUP